

E1

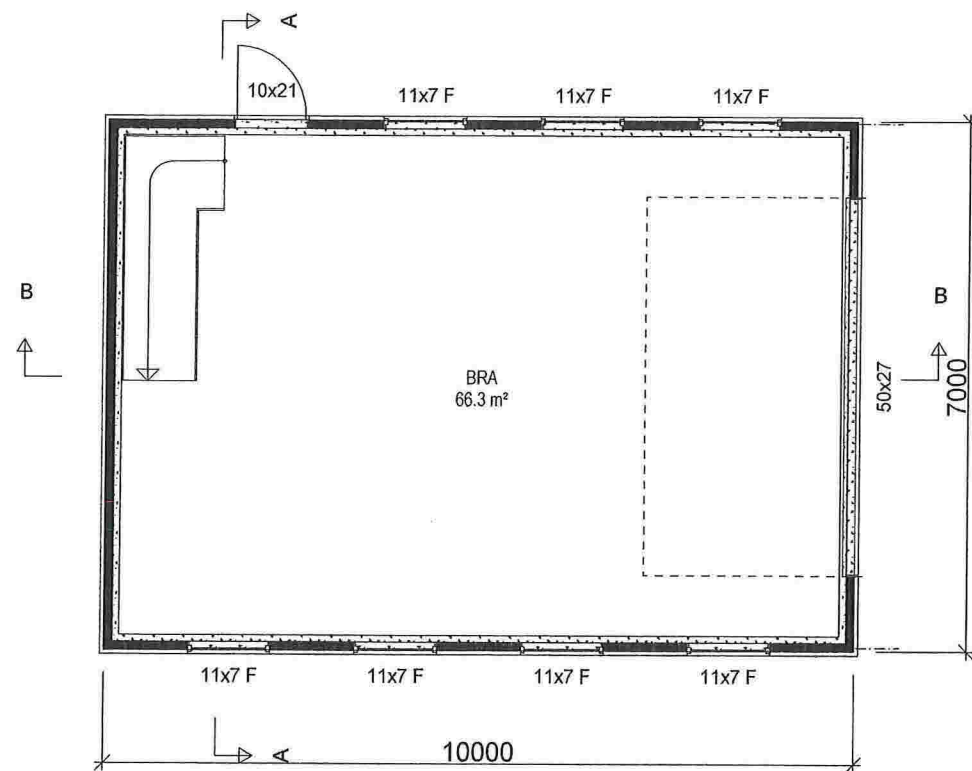

Hovedplan

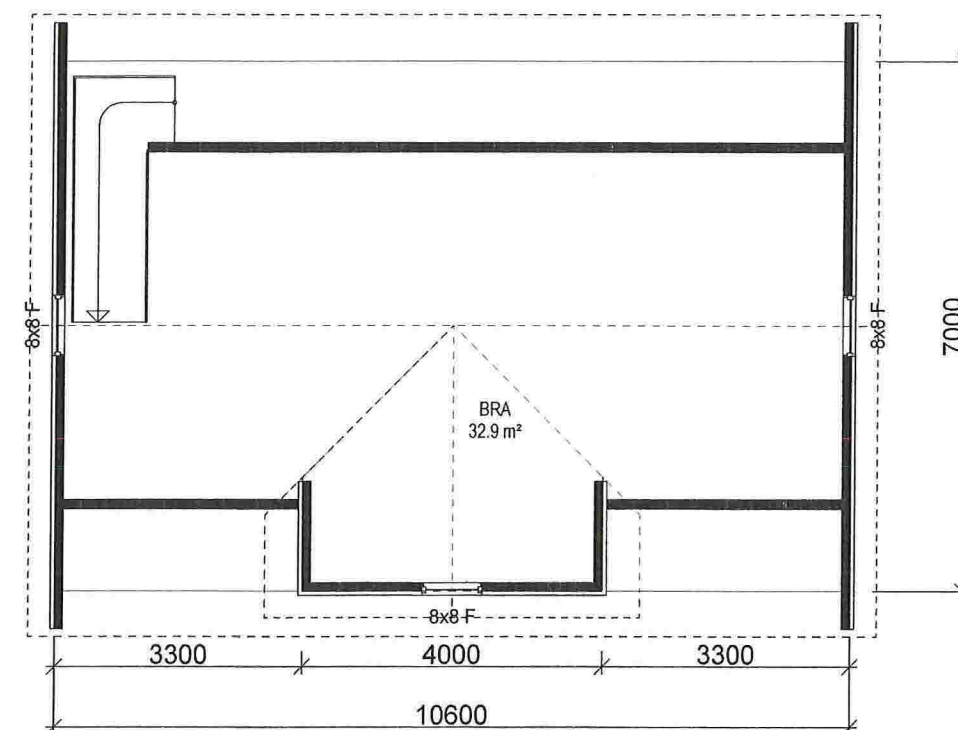

Loftsplan

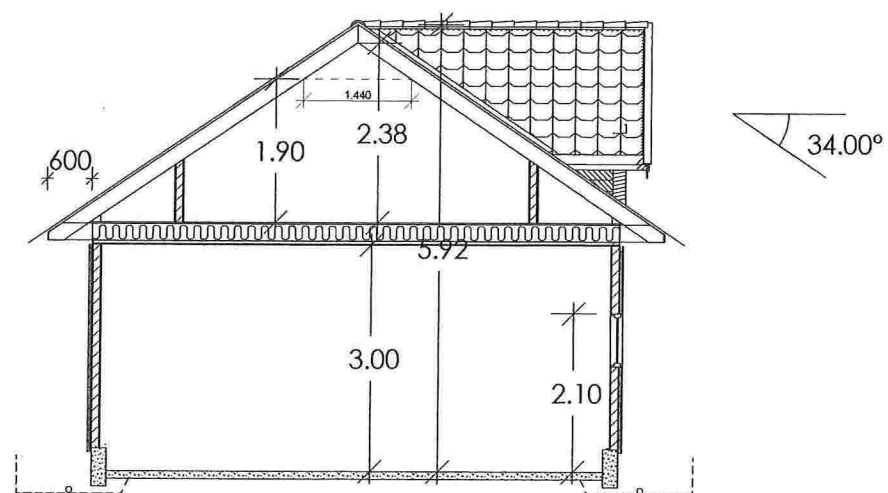

Snitt A - A

Arealberegninger i hht. NS 3940	Bruksareal BRA i m ²		Sum BRA
	Utvendig bod/garasje	Åpent over- bygg areal og carport	
1. etg. plan	66.3	0.0	66.3
2. etg. plan	32.9	0.0	32.9
SUM :	99.2	0.0	99.2
BYA :	71.8	3.8	75.6
Loftbredde v/1.9m	1.4 m		

Garasje

Tømrar Helge Andvik	Tiltakshaver: Jon Andvik/Anne-Signe L. Andvik	Dato: 21.04.2016
5981 Masfjordnes Mob. 90 72 60 26	Byggeplass: Leknesvegen 178, 5915 Hjelmås	Tegn: HA
helge.andvik@nettstar.as	Kommune: Lindås	Prosjekt nr.:
	Gnr. 195 Bnr. 108 Mål: 1 : 100	Tegn.nr.: 501
© Tegningen er beskyttet i.h.t. lov om opphavsrett.	Plan og snitt	j_andvik

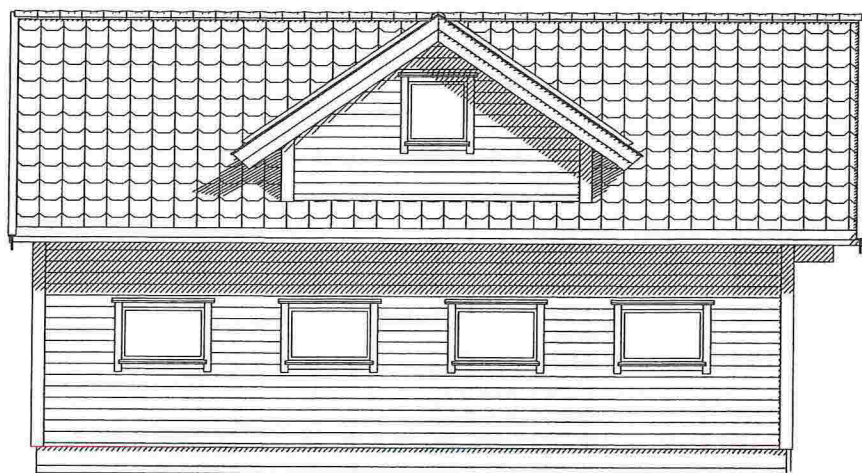

Fasade mot øst

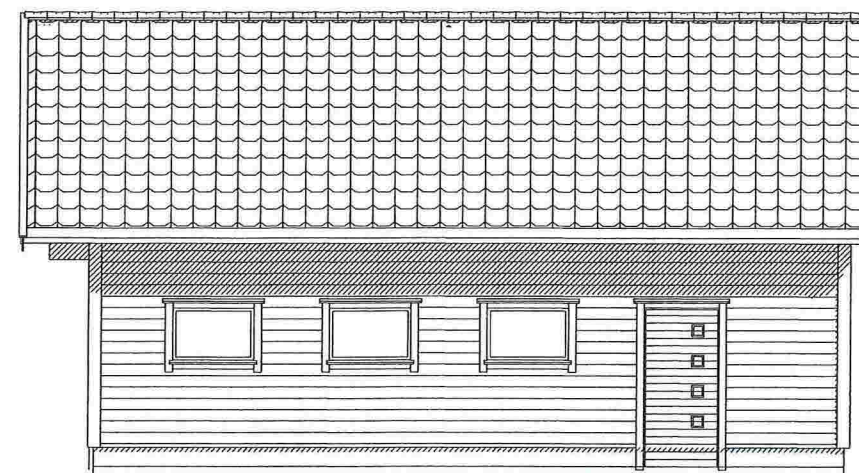

Fasade mot vest

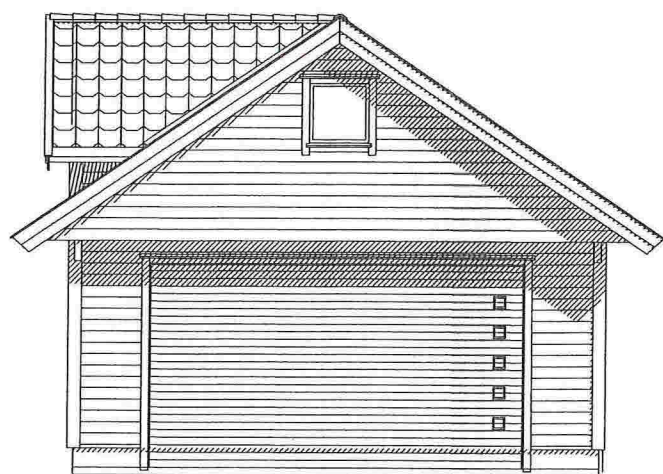

Fasade mot nord

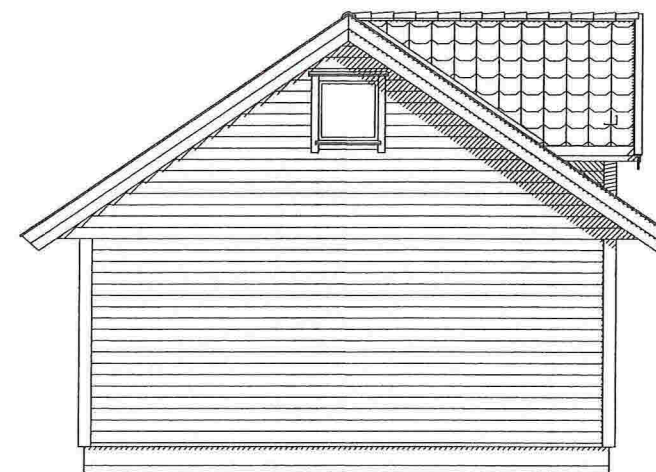

Fasade mot sør

Garasje

<p>Tømrar Helge Andvik 5981 Masfjordnes Mob. 90 72 60 26 helge.andvik@nettstar.as</p>	Tiltakshaver:	Jon Andvik/Anne-Signe L. Andvik	Dato:	19.04.2016
	Byggeplass:	Leknesvegen 178, 5915 Hjelmås	Tegn:	HA
	Kommune:	Lindås	Prosjekt nr.:	
	Gnr. 195 Bnr. 108 Mål: 1 : 100	Fasader	Tegn.nr.:	502
© Tegningen er beskyttet i.h.t. lov om opphavsrett.			j_andvik	

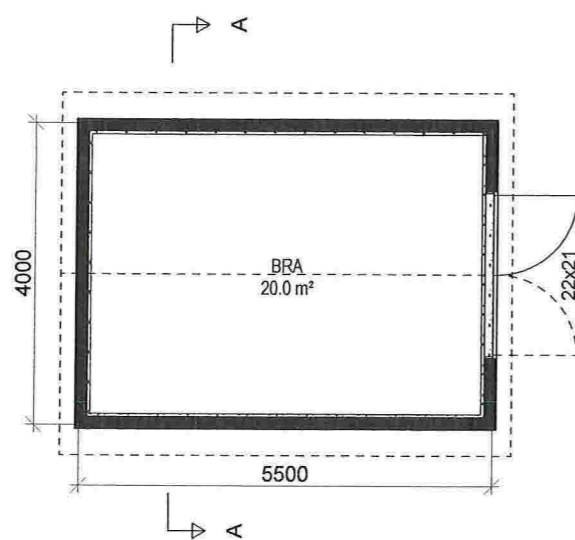
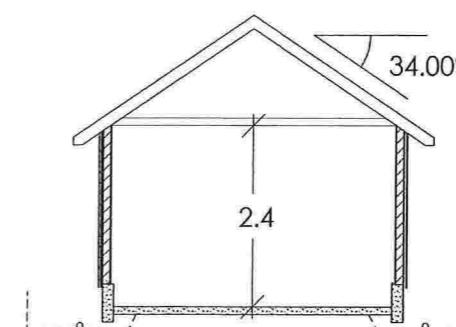
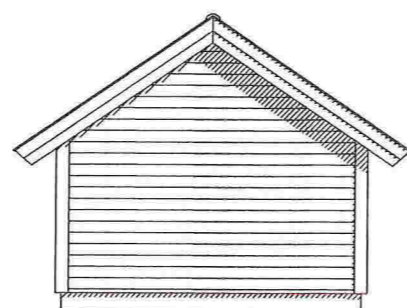
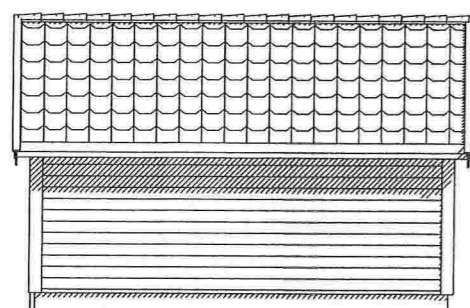
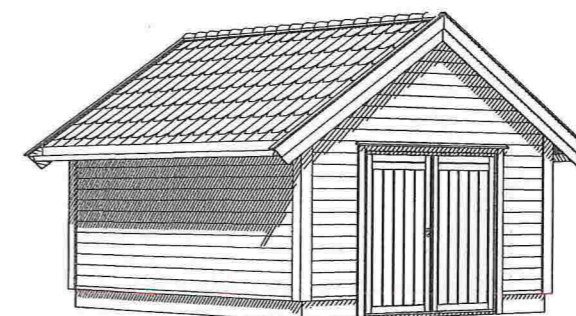
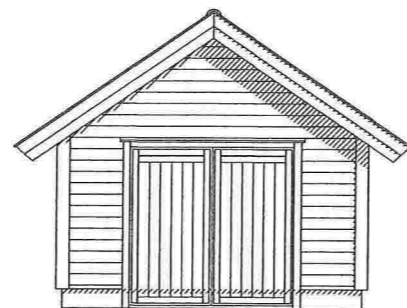
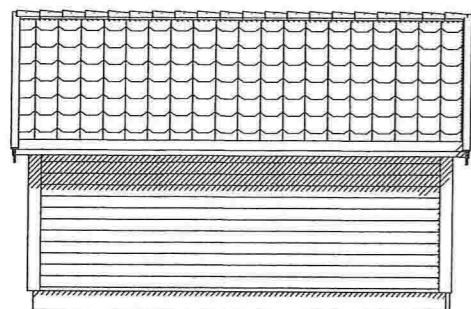

Arealberegninger i hht. NS 3940	Bruksareal BRA i m²	
	Pr etasje	Sum BRA
1. etg. plan	20.0	20.0
SUM :	20.0	20.0
BYA :	22.0	22.0

Bod

Tømrar Helge Andvik 5981 Masfjordnes Mob. 90 72 60 26 helge.andvik@nettstar.as	Tiltakshaver: <u>Jon Andvik og Anne-Signe L. Andvik</u>	Dato: <u>13.12.2016</u>
	Byggeplass: <u>Leknesvegen 178, 5915 Hjelmås</u>	Tegn: <u>HA</u>
	Kommune: <u>Lindås</u>	Prosjekt nr.: _____
	Gnr. <u>195</u> Bnr. <u>108</u> Måt. <u>1 : 100</u>	Tegn.nr. <u>502</u>
	Plann, Snitt og fasader	j_andvik_bod