

Gnr 51	Bnr 139	Føstennr
Representasjonspunkt X 289662 Y -53032 Z		
Kartblad AE061-1-46	X	Landsnett
Målestokk 1: 500	Areal 560 M ²	

MÅLEBREVKART

Jnr
Målebrev nr 9736

IN

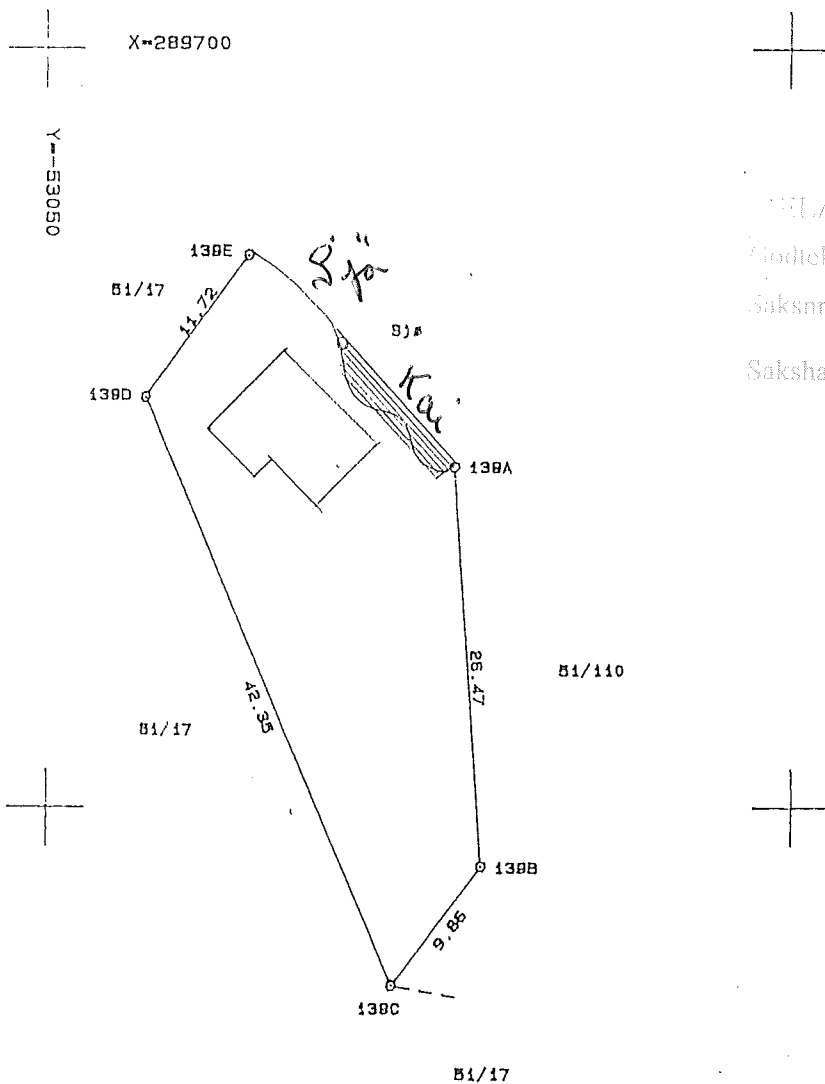

ISLAND KOMMUNE

Dato: 17/10-2014

Saksnr. DNT sak 298/2014

Sakshandsamar e.f. *AD*

PUNKT	PUNKTMERKE	X-KOORD	Y-KOORD	SIDE/BUE	RADIUS
51139A	Gkj bolt fjell	289672.46	-53022.50	26.47	
51139B	Gkj bolt fjell	289646.05	-53020.77	9.86	
51139C	Gkj bolt fjell	289638.19	-53026.73	42.35	
51139D	Kross i fjell	289677.14	-53043.37	11.72	
51139E	Jernstolpe	289686.46	-53036.26		

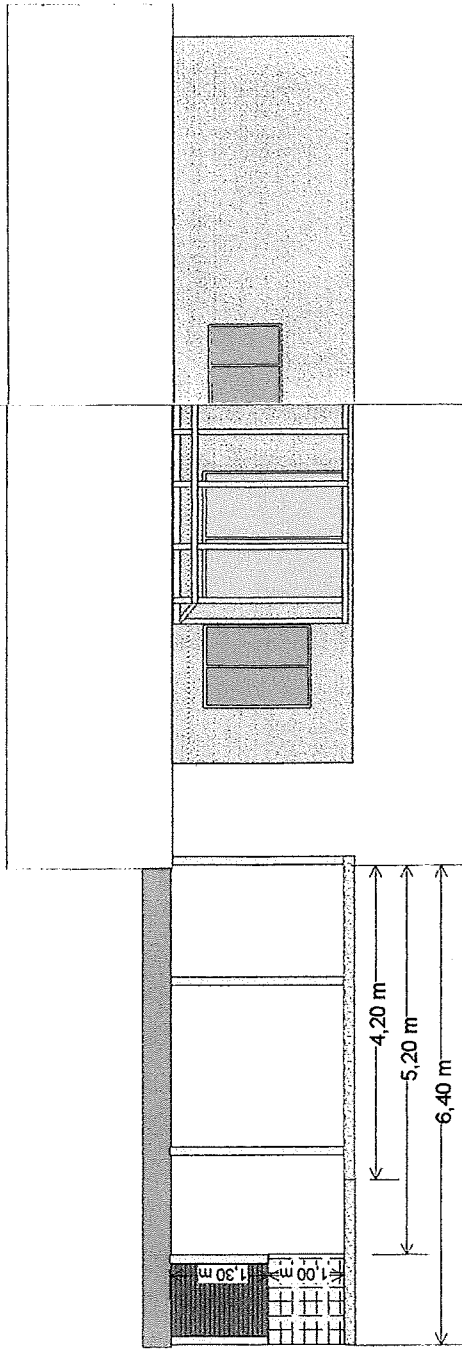

Sett fra nordøst

MELAND KOMMUNE
 Godtjcke 17/10-2014
 Saksnr. DNT sak 298/2014

Sakshandsamar e.f.

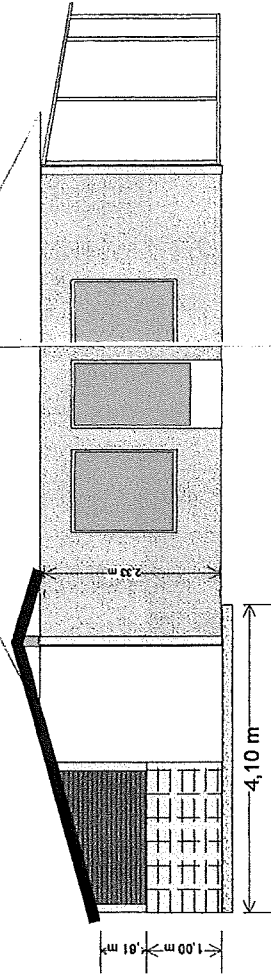

Sett fra sørøst

Tak over terrasse utenfor hytte til N. S. Tellevik	
Fasader	Stokk: 1:100
Dato: 09.05.2014	Revisjon nr: 2

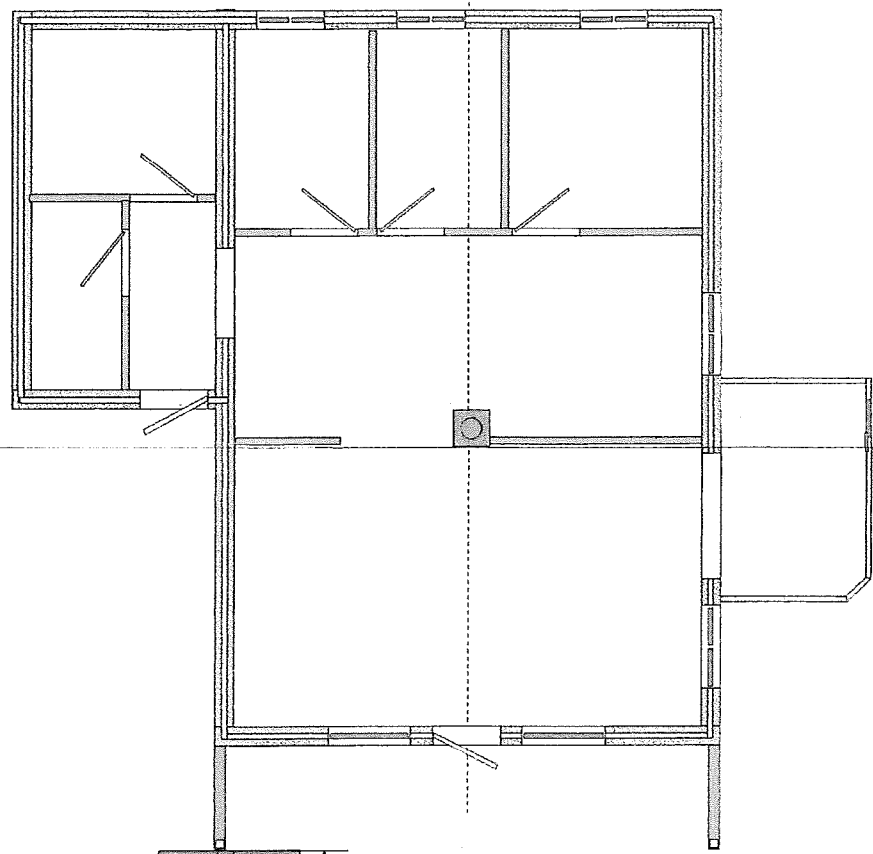
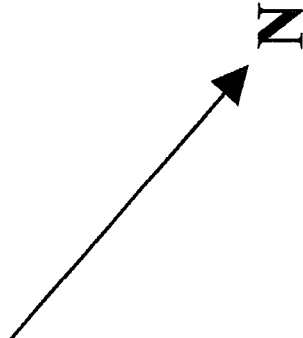
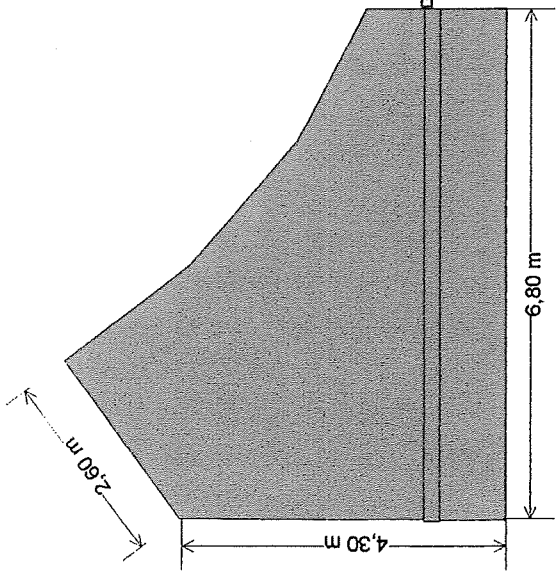

MELAND KOMMUNE
 Godteke 17/10-2014
 DNT sak 51/139 298/2014
 kshandsamar e.f. *RD*

Tak over terrasse utenfor hytte til N. S. Tellevik	
Takflate	Skala: 1:100
Date: 09.05.2014	Revisjon nr: 2

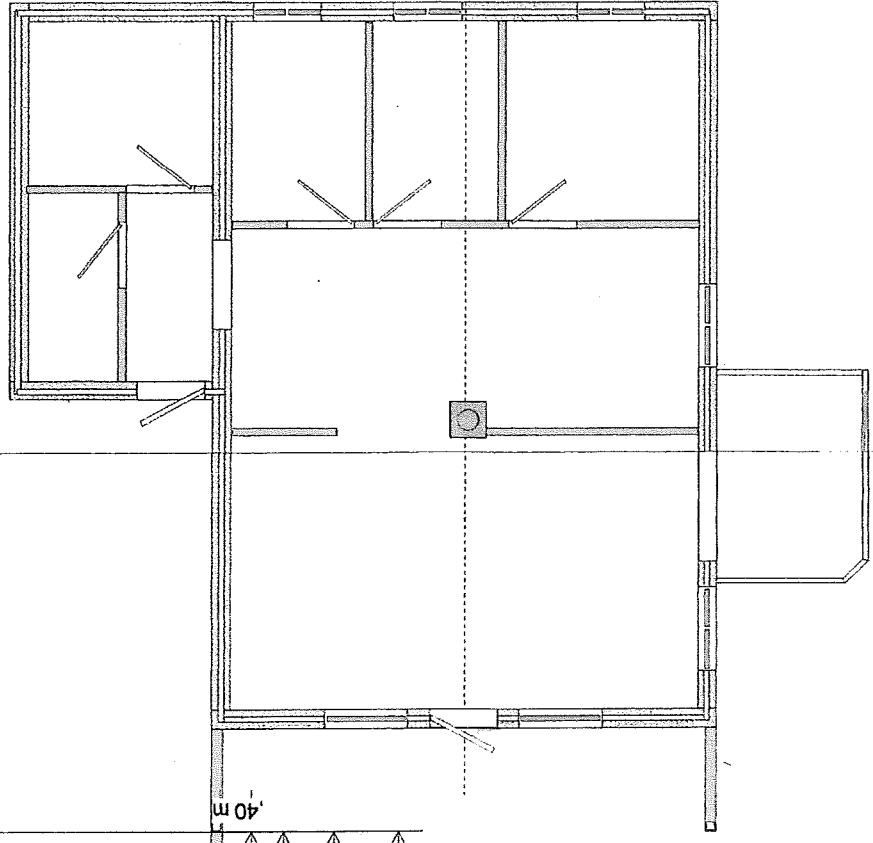
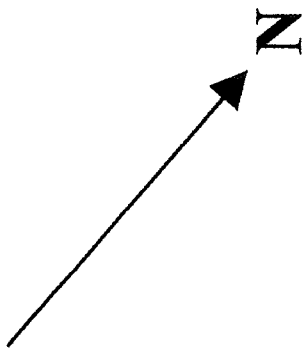
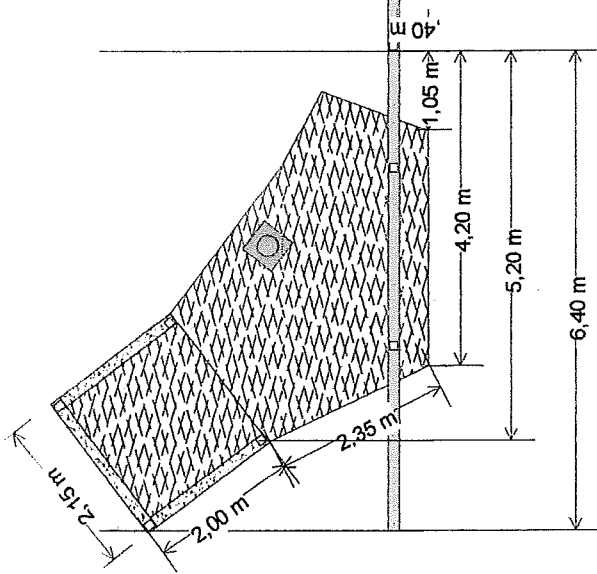

MELAND KOMMUNE

Godteke 17/10-2014

Saksnr. DNT sak 51/139 298/2014

Sakshandsamar e.f. *HO*

Tak over terrasse utenfor hytte til N. S. Tellevik	
Skala:	1:100
Date:	09.05.2014
Revisjon nr:	2
Grunnflate og takbjelke	

SITUASJONSKART

Gnr/Bnr: 51-126
Adresse: Havrevågen 12
Eigar/søkar: Bjørn Ove Fedje

Kvalitet: FKB-C

Gjeldande plan: Kommuneplan
Planformål: LNF

Vår referanse: pas



Sign.



MELAND
KOMMUNE



Målestokk: 1:1000
Dato: 30.05.2008

- // — // Gjerde
- - - - Usikker eigedomsgrænse
- — — — Målt eigedomsgrænse
-  Bolighus
-  Andre bygg

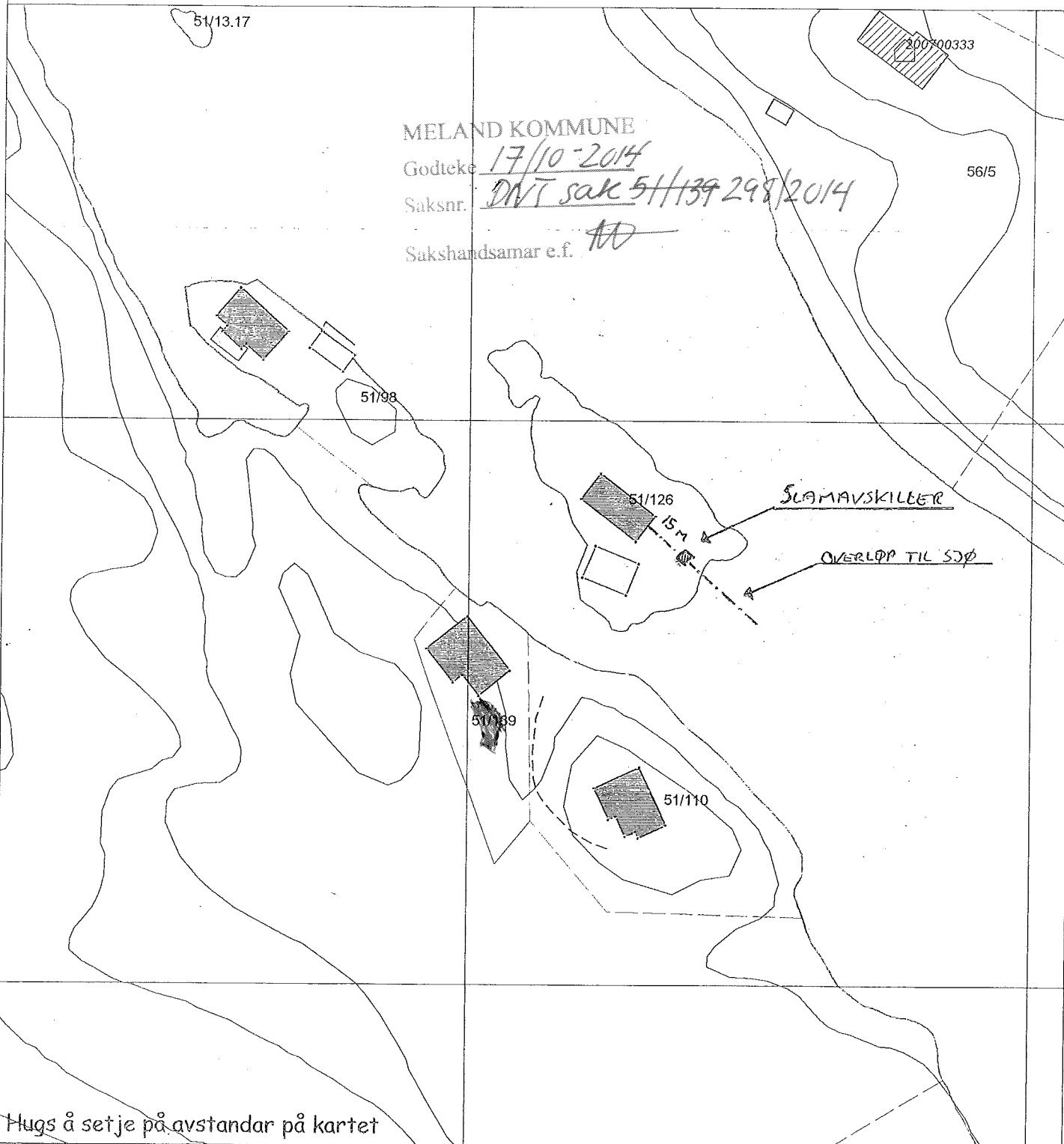

Hugs å setje på avstandar på kartet

SITUASJONSPLAN

 Tiltak

Roz Glog 9/6-08
Underskrift Situasjonsplan Dato