

Plan 1. etg

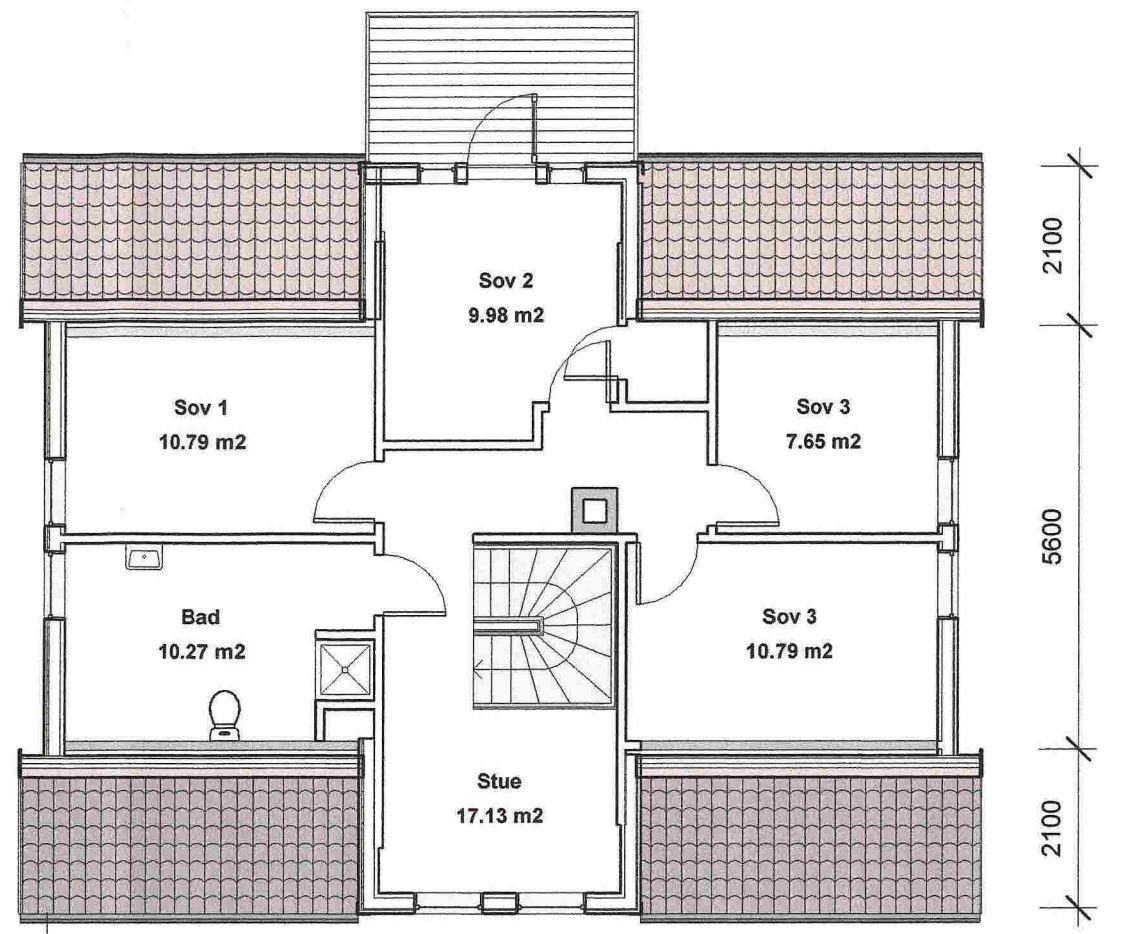

Plan 2. etg

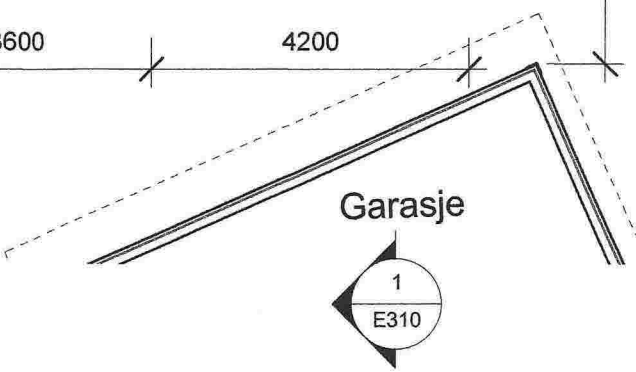

Bebygdareal BYA	
Navn	Areal

Bolig	102 m ²
Garasje	45 m ²
Terrasse, 2. etg	7 m ²
Tak over inngang	3 m ²
Grand total: 4	157 m²

Bruksareal BRA	
Navn	Areal

Tak over inngang	4 m ²
Garasje	42 m ²
2. etg	74 m ²
1. etg	89 m ²
Grand total: 4	209 m²

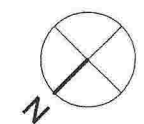

ENEBOLIG	Planer	Mål 1:100 / A3
Gnr 23, Bnr 500, Frekhaug Meland kommune P.nr 1511	EKSISTERENDE FORHOLD Kristin Brakstad Traa og Per Arne Traa Holtermandsvegen 12 B, 5918 Frekhaug	Tegn.nr E301
Arkitekt Mette Kyed Thorson	Sivilarkitekt MNAL Medlem av Arkitektbedriftene Kvalen 16, N-5955 Lindås Tlf +47 901 48 834 mktho@online.no	Rev B
		Dato 25.11.2015

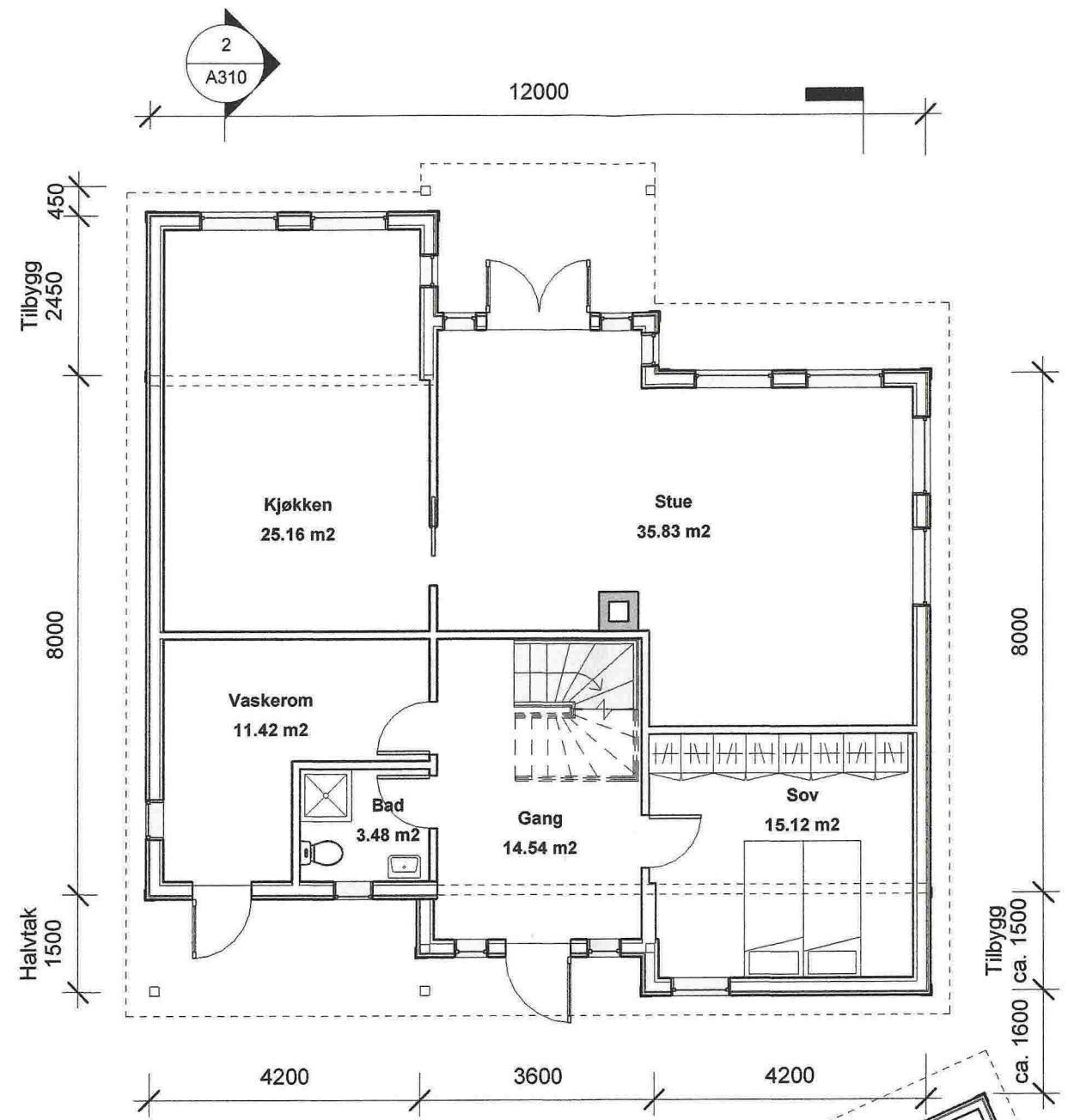

Plan 1. etg

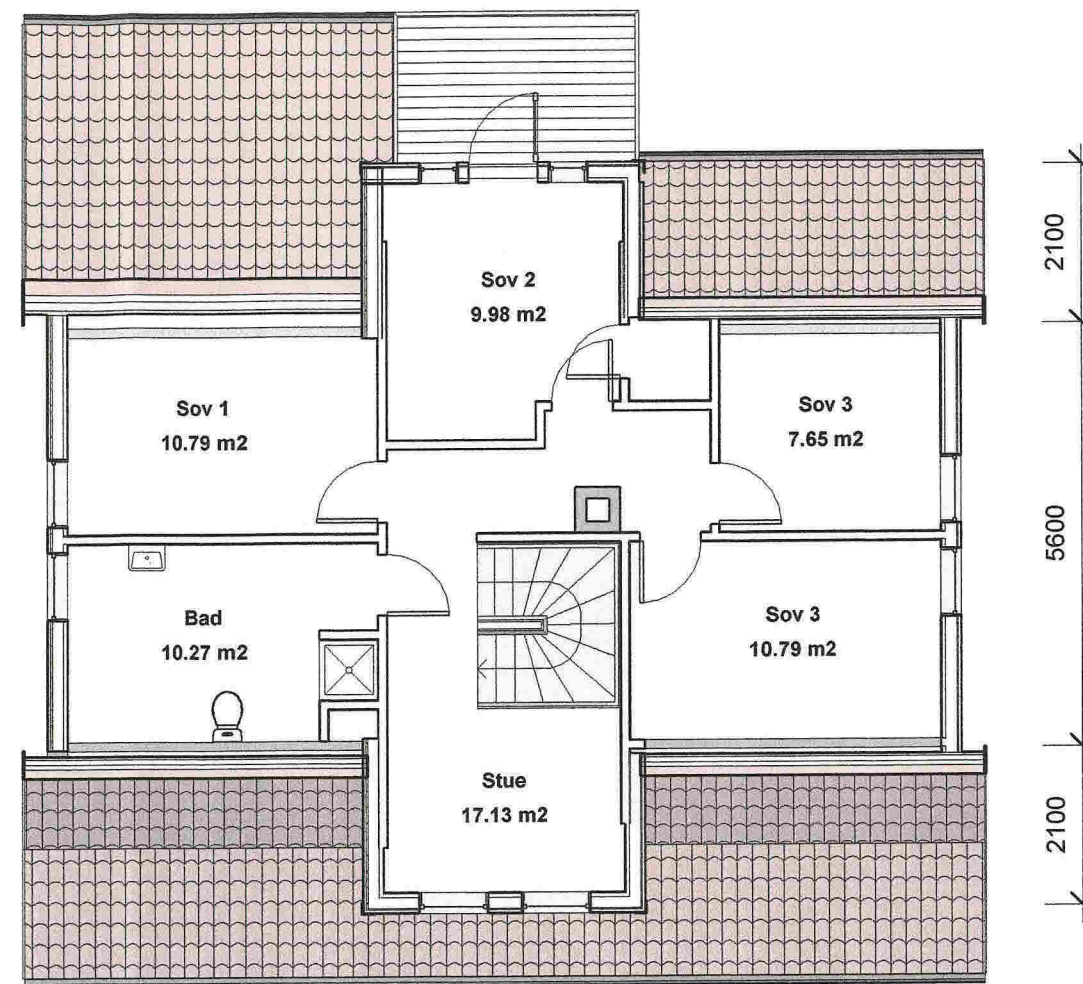

Plan 2. etg

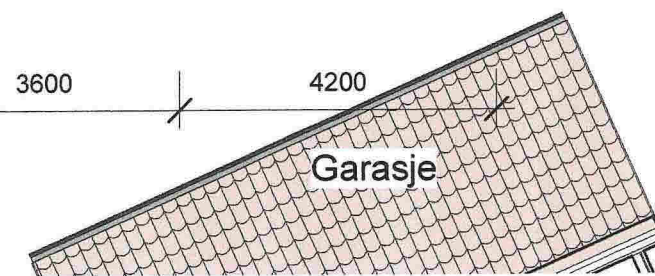
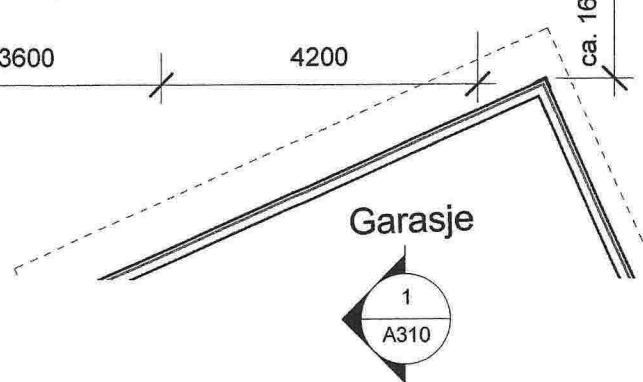

Bebyggdareal BYA	
Navn	Areal

Bolig	101 m ²
Garasje	45 m ²
Tilbygg kjøkken	9 m ²
Tilbygg, sov/vf	9 m ²
Tak over inngang	9 m ²
Terrasse, 2. etg	7 m ²
Grand total: 6	180 m²

Bruksareal BRA	
Navn	Areal

Tak over inngang	10 m ²
Tilbygg, soverom	10 m ²
Tilbygg, kjøkken	11 m ²
Garasje	42 m ²
2. etg	74 m ²
1. etg	89 m ²
Grand total: 6	236 m²

ENEBOLIG

Gnr 23, Bnr 500, Frekhaug
Meland kommune
P.nr 1511

Arkitekt Mette Kyed Thorson

Planer

SØKNAD OM TILBYGG
Kristin Brakstad Traa og Per Arne Traa
Holtermansvegen 12 B, 5918 Frekhaug

Sivilarkitekt MNAL Medlem av Arkitektbedriftene Org.nr 987 788 682
Kvalen 16, N-5955 Lindås Tlf +47 901 48 834 mktho@online.no

Mål 1 : 100 / A3

Tegn.nr A301

Rev D

Dato 25.11.2015

