

NORMALPROFIL Fv391 - LEIKNESVEGEN
 Veg o_V
 M=1:50

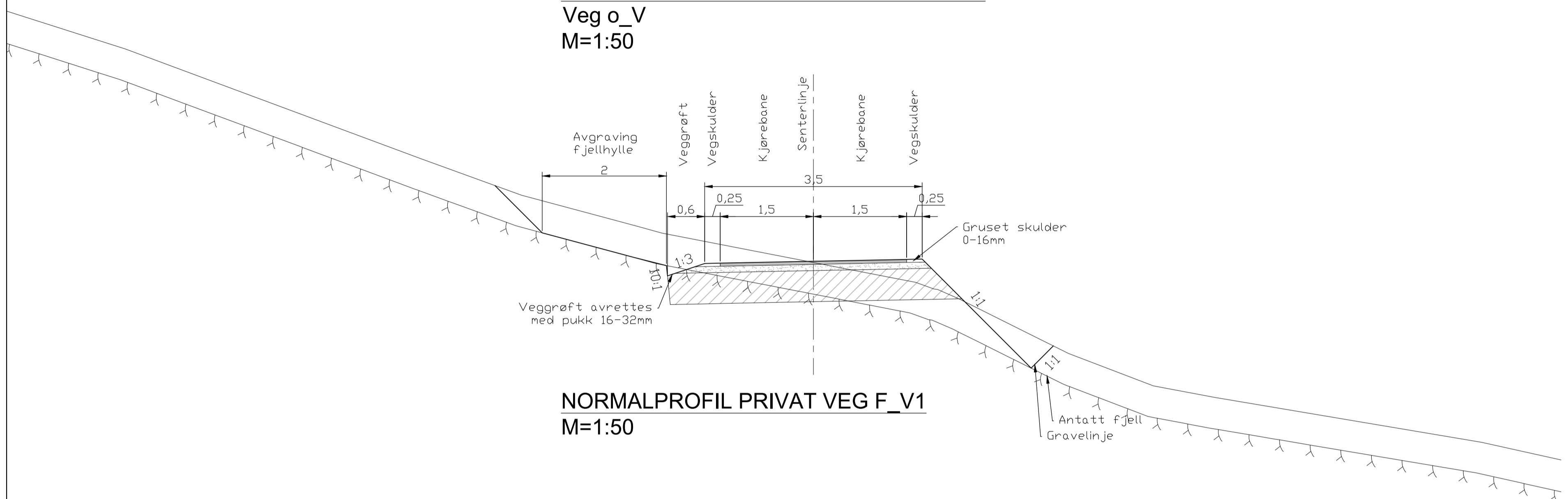

NORMALPROFIL PRIVAT VEG F_V1
 M=1:50

OVERBYGNING VEGBANE

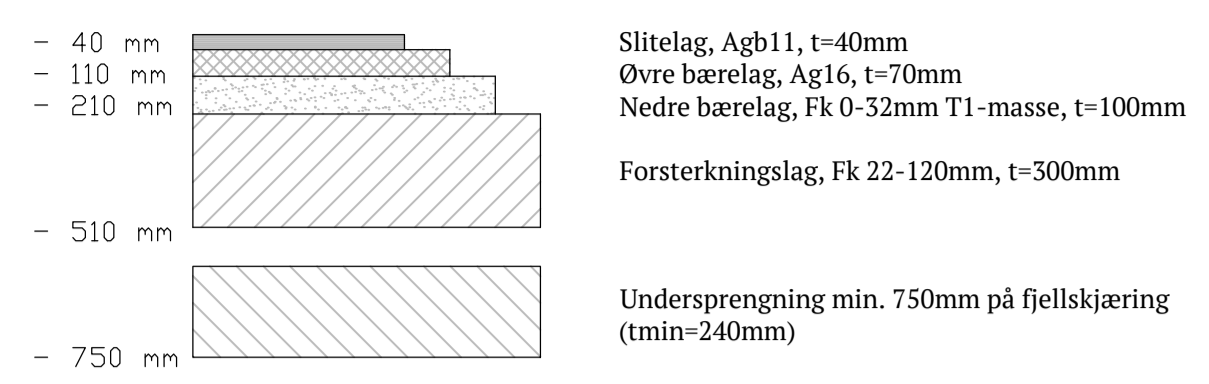

OVERBYGNING FORTAU

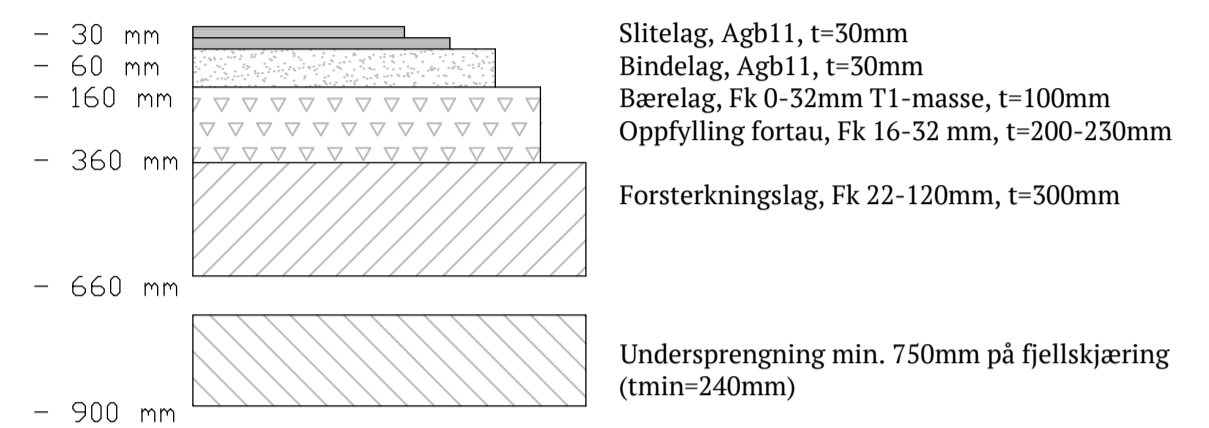

OVERBYGNING PRIVAT VEG OG PARKERINGSPLASS

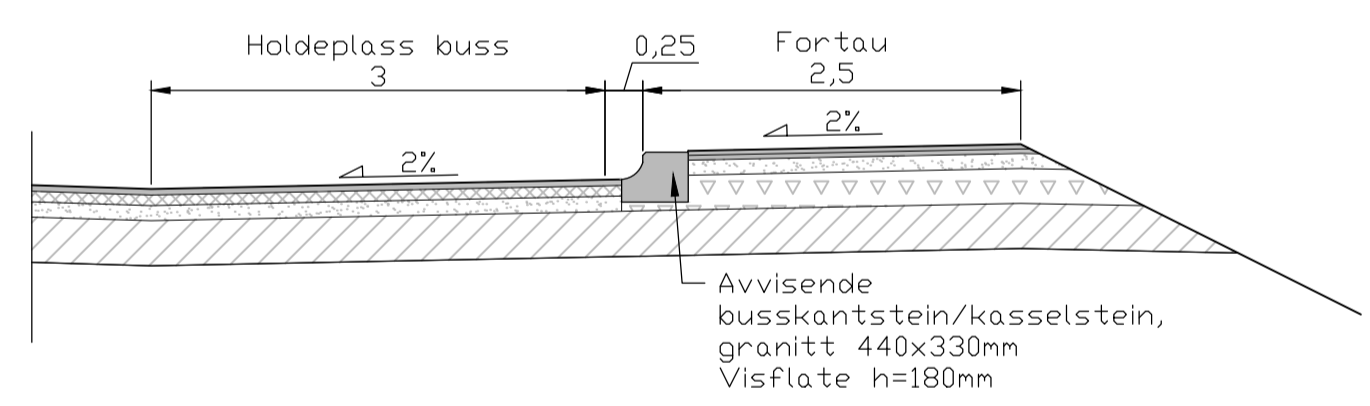
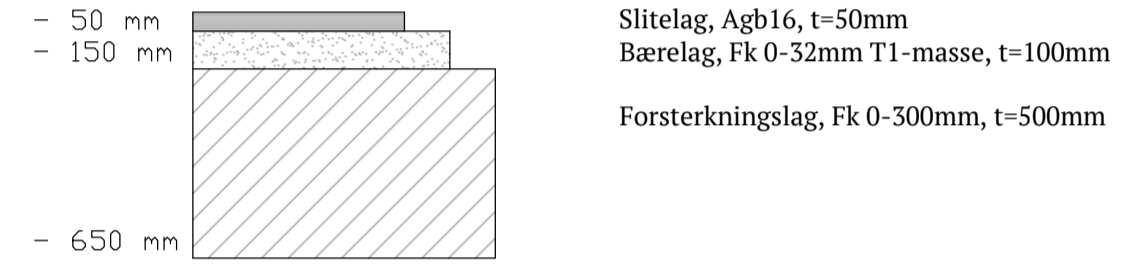

SNITT BUSSHOLDEPlass
 M=1:50
 Lengde=20m
 Utvidelse og innsnevring over 15m

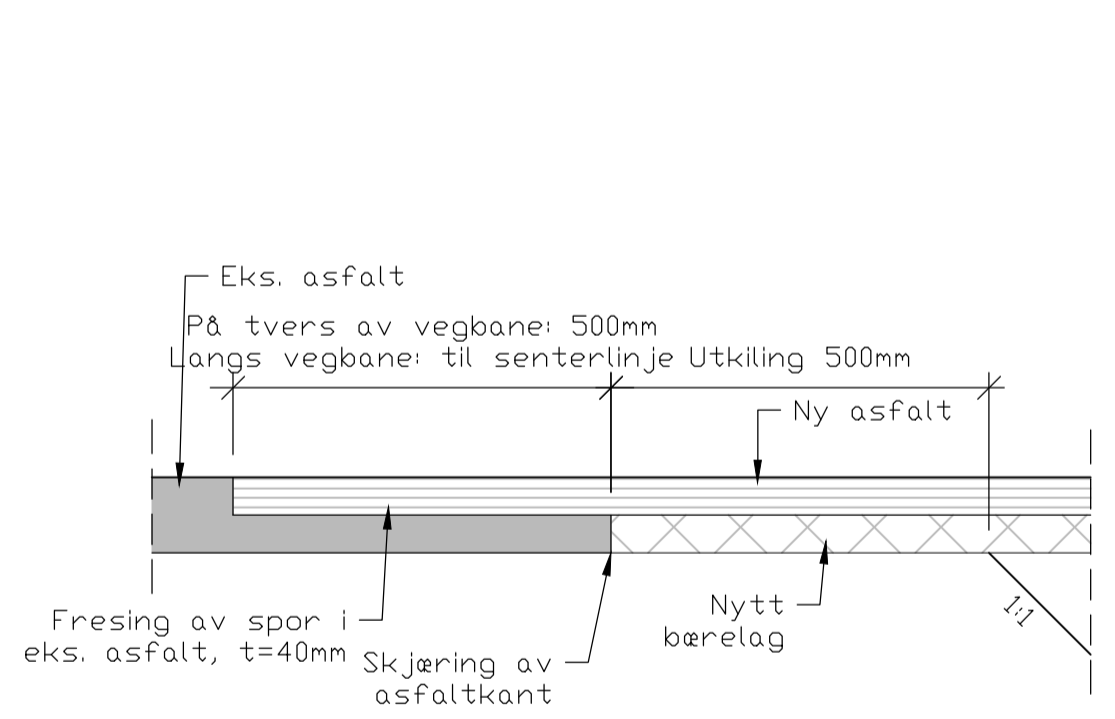

OVERGANG EKISTERENDE/ NY ASFALT
 M=1:10

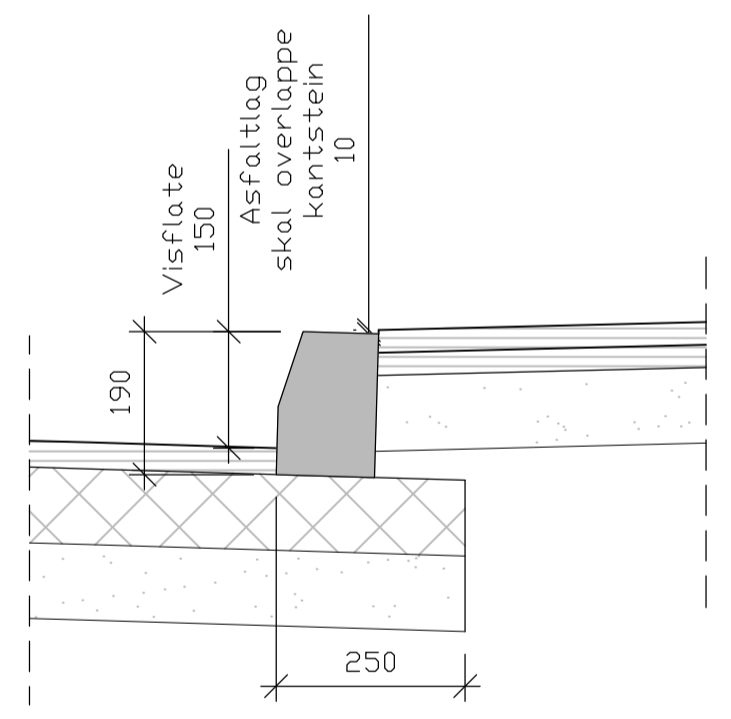

AVSLUTNING ASFALT MOT FORTAUSKANT
 M=1:10

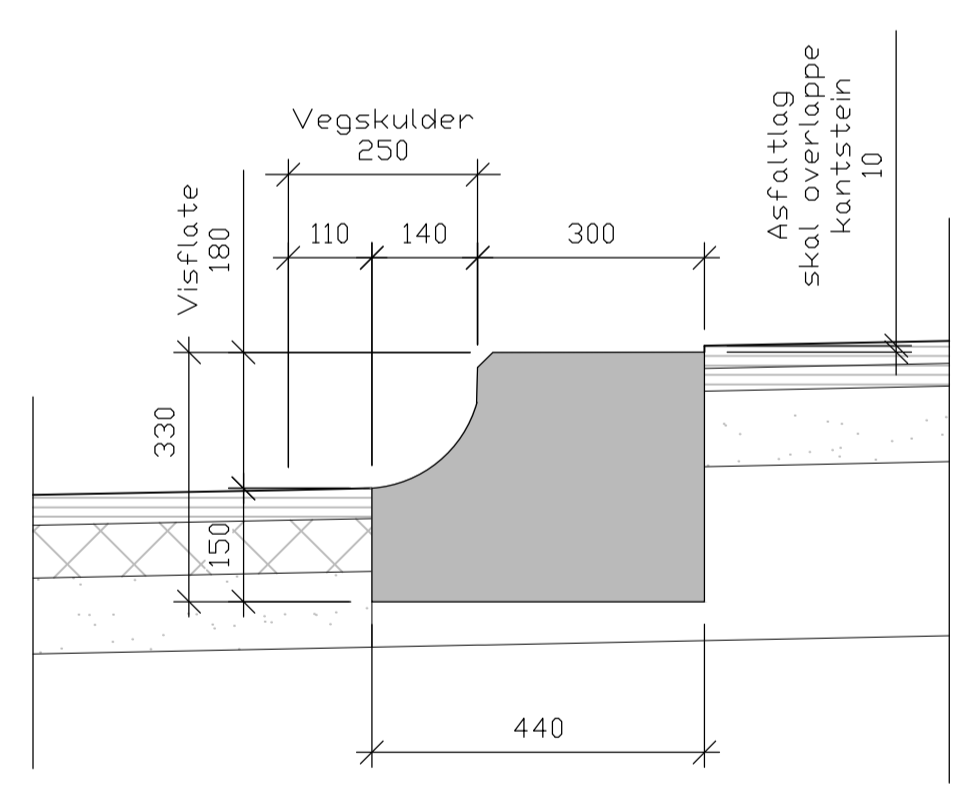

AVSLUTNING ASFALT MOT KASSELKANTSTEIN
 M=1:10

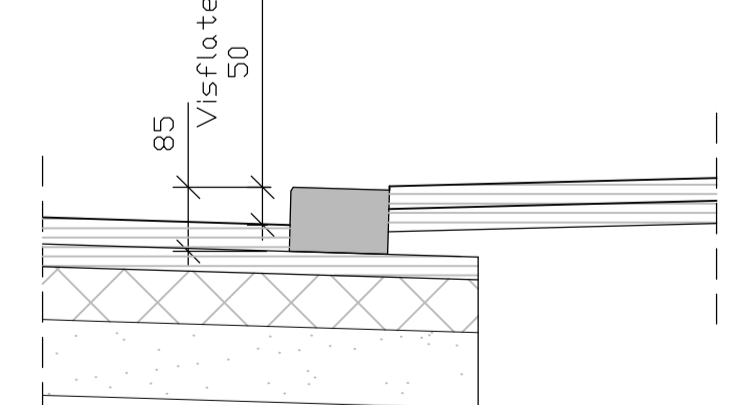

NEDSENKET FORTAUSKANT I AVKJØRSLER
 M=1:10

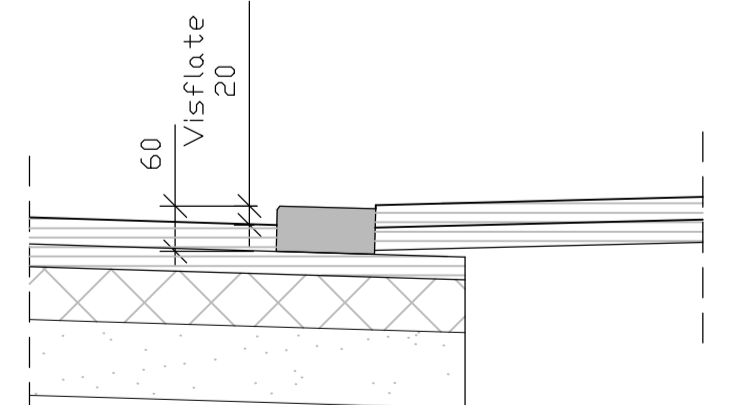

NEDSENKET FORTAUSKANT I KRYSNINGSPUNKT FOR FOTJENGERE
 M=1:10

ARBEIDSTEGNING

Rev.	Dato	Sign.	Revisjonen gjelder		
Oppdragsgiver					
LEKNESTUNET AS					
Prosjekt	HILLESVÅG BUSTADFELT.			Tegn.	THF
Normalprofil vegger.				Kontr.	ANH
Date: 06.05.2019				Godk.	THF
Målestokk: 1:10, 1:50				Formater	A1
Prosjekt: 19017				Tegning	FO1
				Kanalveien 5 5068 Bergen Tlf. 55 59 82 60 e-post: post@haugenvva.no	