

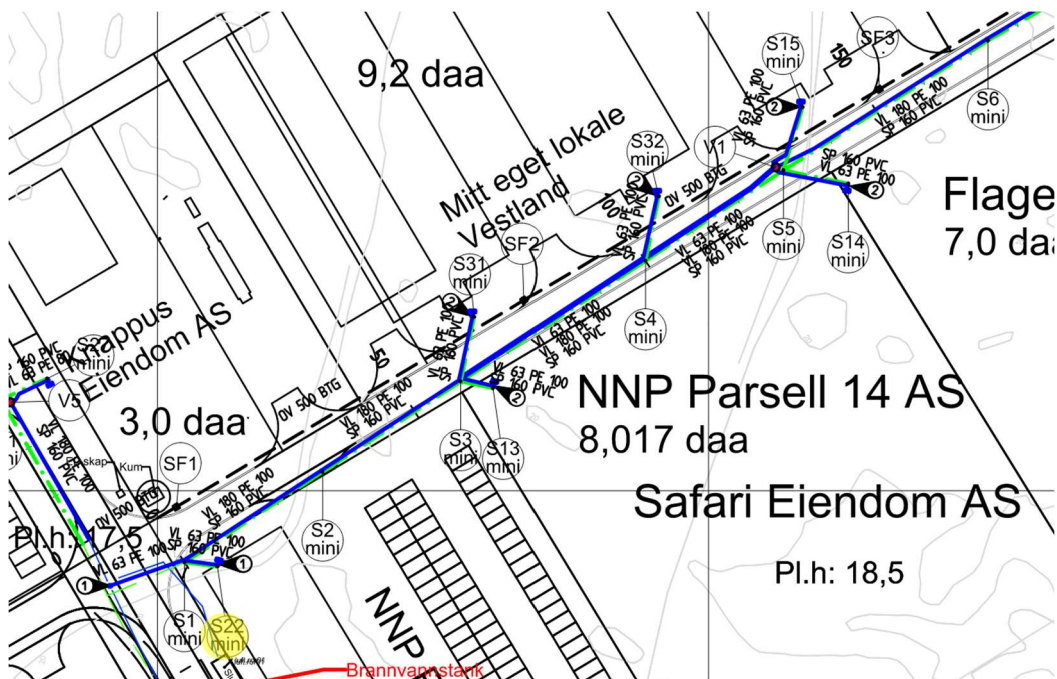

<b>Kumkort</b>			
Tiltakshaver:	ATR eiendom,	Side:	<b>1 av 4</b>
Ansvarlig utførende:	Flage Maskin as	Sist rev.	18.02.2022
Prosjekt:	Nordhordaland Næringspark VA	Dok.Id:	030610-061 B
Prosjektnr.:	21033	Dato /sign.:	

<b>Anleggssted</b>	Nordhordaland Næringspark
<b>Dato</b>	18.02.2022
<b>Registrert av</b>	Mari Røen
<b>Kumnr.</b>	S22



## KUMDATA

<b>Kumform</b>	R (Rund)
<b>Kumbredde</b> Innvendig diameter (mm)	400
<b>Bunnseksjon</b>	Rettløp
<b>Kjegle</b>	U (uten kjegle)
<b>Byggetype</b>	W (PP (polypropylen))
<b>Produsent</b>	Kaczmarek
<b>Stige</b>	Nei
<b>Drenering</b>	U (ingen drenering)

<b>Kumkort</b>		 <small>Bjørkemoen 46 5700 VCS T.L.F. 56 63 02 00 – FAX 56 63 02 10 MOB 46 40 70 70 – www.flagemaskin.no</small>	
Tiltakshaver:	ATR eiendom,	Side:	<b>2 av 4</b>
Ansvarlig utførende:	Flage Maskin as	Sist rev.	18.02.2022
Prosjekt:	Nordhordaland Næringspark VA	Dok.Id:	030610-061 B
Prosjektnr.:	21033	Dato /sign.:	

### Kumskisse, bilde nr. 1

Kommentar til skisse: Bunnseksjon har **rettløp**

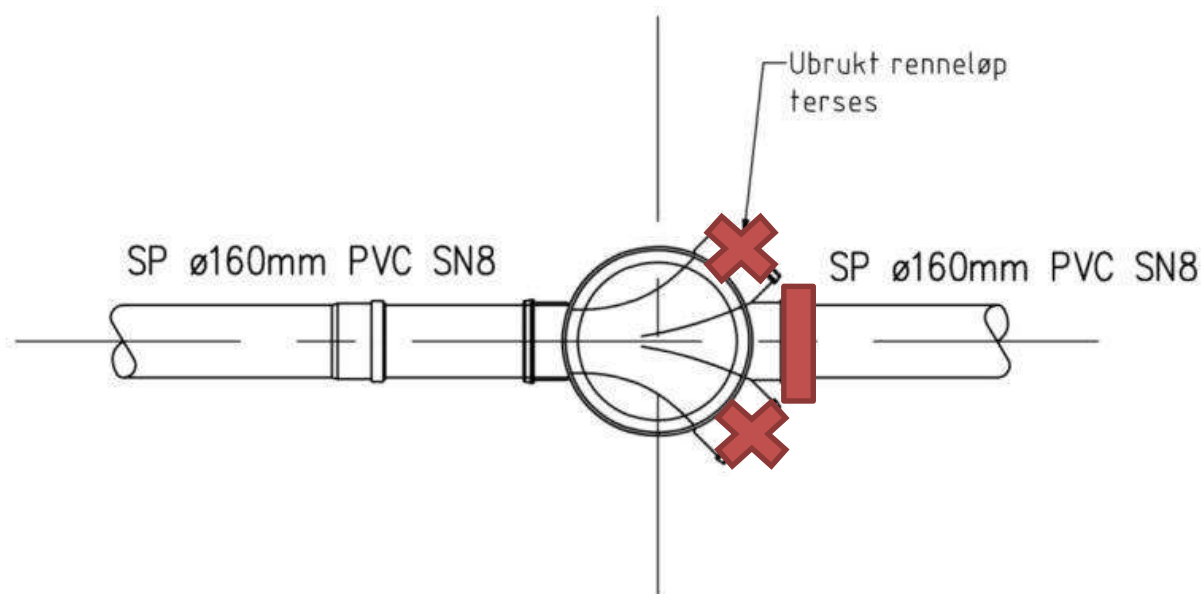

**PLAN MINISTAKEKUM**

18.02.2022 14:14

**M=1:20**

<b>Kumkort</b>			
Tiltakshaver:	ATR eiendom,	Side:	<b>3 av 4</b>
Ansvarlig utførende:	Flage Maskin as	Sist rev.	18.02.2022
Prosjekt:	Nordhordaland Næringspark VA	Dok.Id:	030610-061 B
Prosjektnr.:	21033	Dato /sign.:	

## Kumskisse, bilde nr. 2

Kommentar til skisse: Bunnseksjon har rettløp

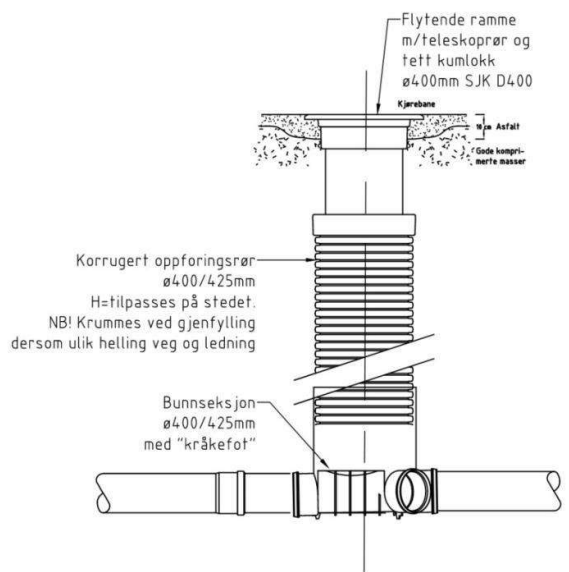

**SNITT MINISTAKEKUM**  
**M=1:20**

18.02.2022 14:14



<b>Kumkort</b>		 <small>Bjørkemoen 46 5700 VCS TLF.55 63 02 00 – FAX.55 63 02 10 MOB.46 40 70 70 – www.flagemaskin.no</small>	
Tiltakshaver:	ATR eiendom,	Side:	<b>4 av 4</b>
Ansvarlig utførende:	Flage Maskin as	Sist rev.	18.02.2022
Prosjekt:	Nordhordaland Næringspark VA	Dok.Id:	030610-061 B
Prosjektnr.:	21033	Dato /sign.:	

