

MESANIN

1: 100

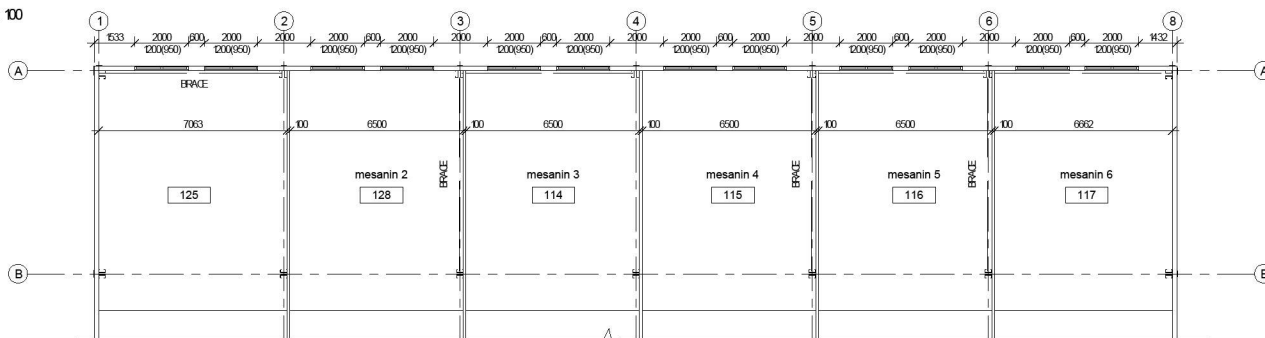

GROUND FLOOR

1: 100

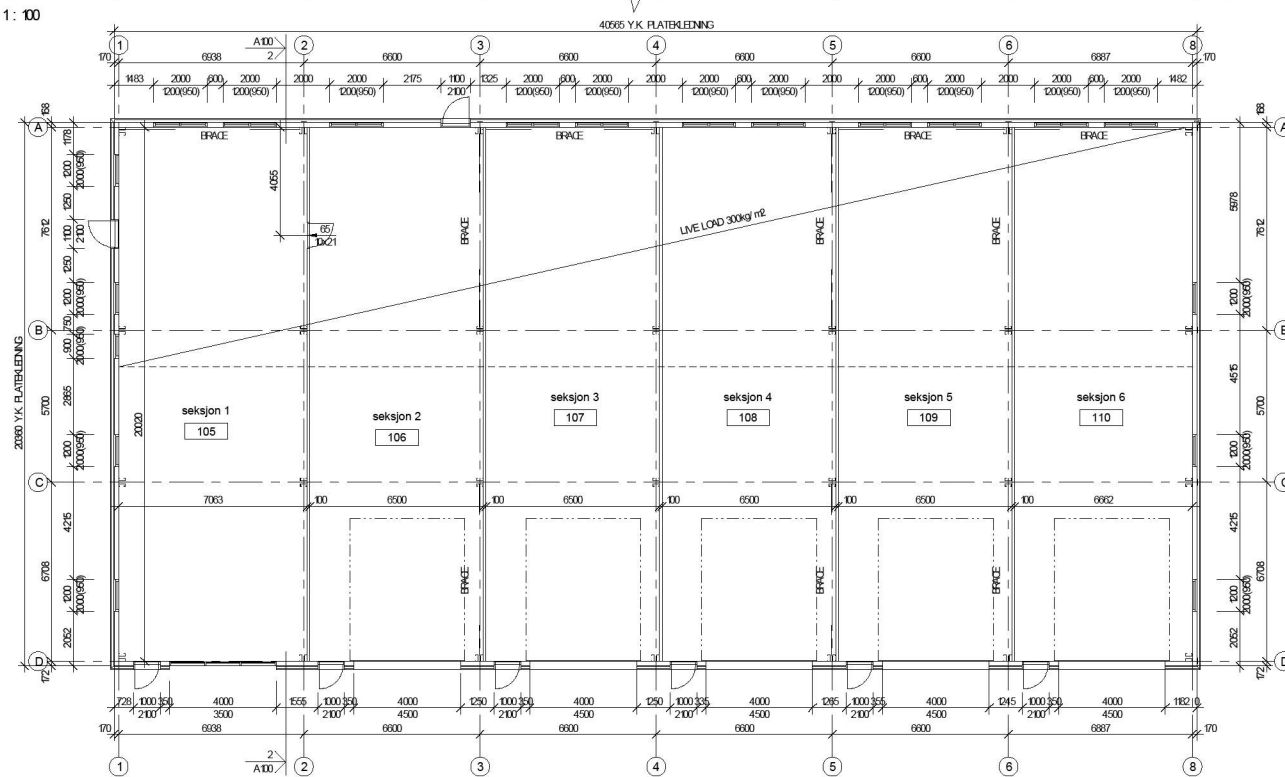

SEKSJON 1: 100

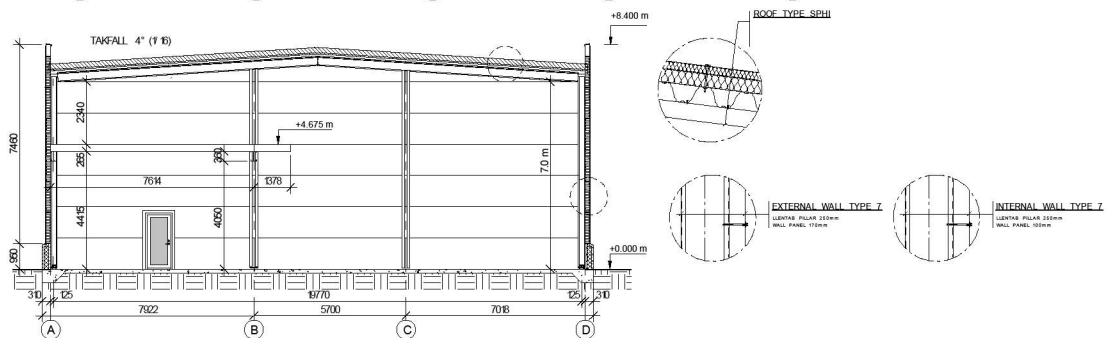

| | | | |
|---|---------------|-----|------|
| REF | AKRÖGGLÖSER | REN | OSMA |
| EJ KLAR | | | |
| LLENTAB | | | |
| LLENTAB Årådensvägen 486 34 Kungälv | | | |
| PHONE +46 523 790 00 E-MAIL info@l Lentab.se WWW.LLENTAB.SE | | | |
| BYGGH NEW PROJEKT FAST NEW KOMMN NEW TOWN | | | |
| ANSVARIG ARKITEKT NICKERSON 2021.05.11 PROJEKTOR | | | |
| PLAN SEKSJON | | | |
| SKALA 1:100 | NUMER A100 | REF | |

FASADE I LINJE A

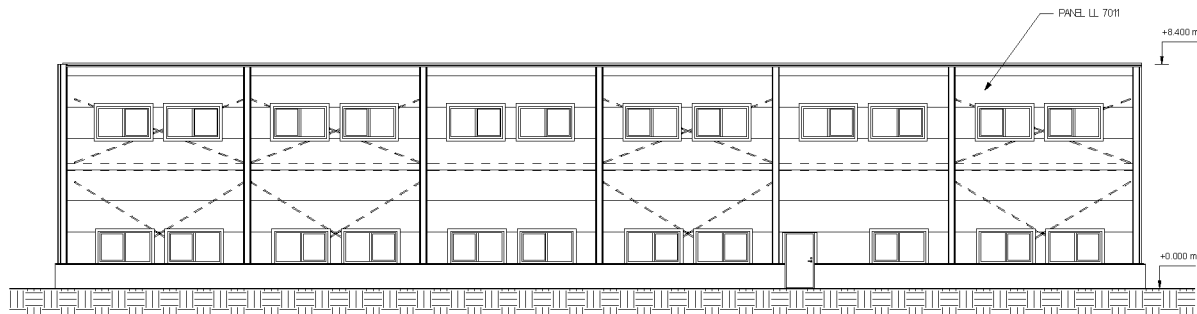

FASADE I LINJE 1

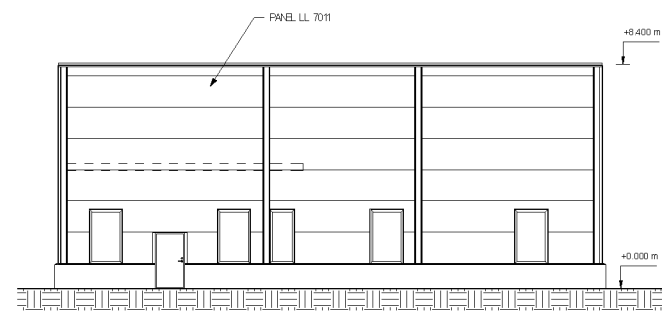

FASADE I LINJE D

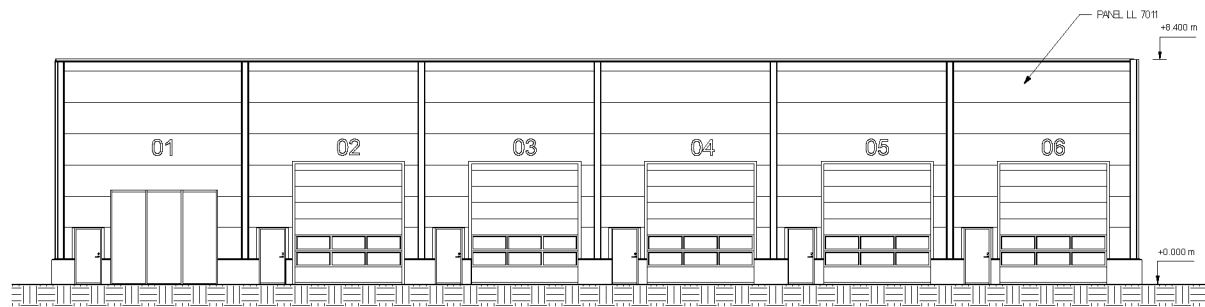

FASADE I LINJE 8

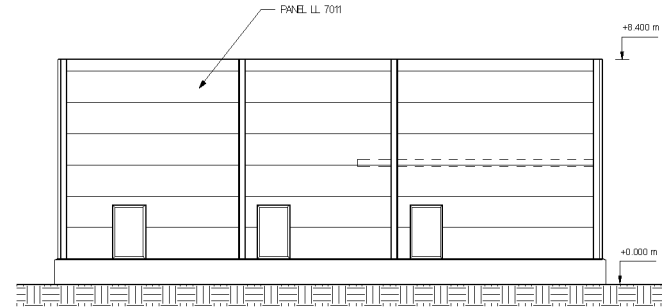

| | | | | |
|--|------------|----------------|------|-------|
| SET | | LENTAB 01/2018 | SEN | OSTAN |
| EJ KLAR | | | | |
| LENTAB AB Hålsjöbergsgatan 29 456 34 Kungälv PHONE +46 523 760 00 EMAIL info@lentab.se | | | | |
|  WWW.LENTAB.SE | | | | |
| BYGGH | NEWPROJEKT | | | |
| FAST | NEW | | | |
| KOMMUN | NEWTOWN | | | |
| PROJEKTANT | PROJEKTANT | | | |
| 2018-05-11 | Uppskrift | | | |
| LANGSIEDER | | | | |
| SKALA | 1:100 | FORMAT | A300 | SET |

FASADE I LINJE A 1: 100

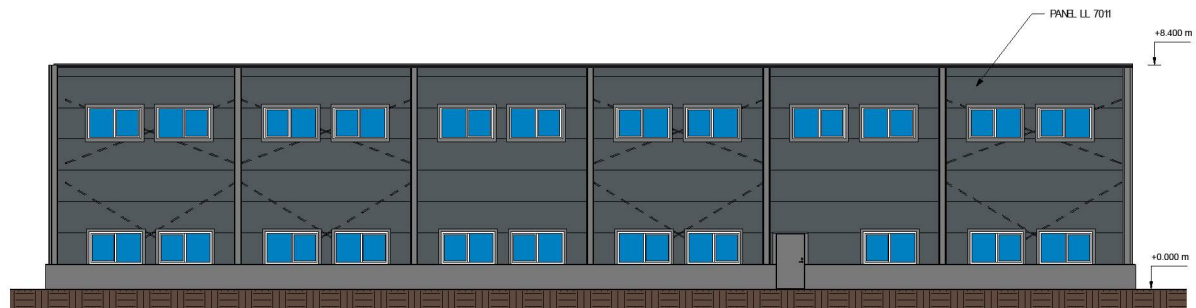

FASADE I LINJE 1 1: 100

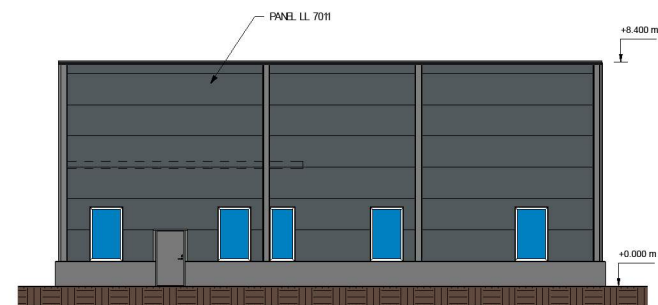

FASADE I LINJE D 1: 100



FASADE I LINJE 8 1: 100

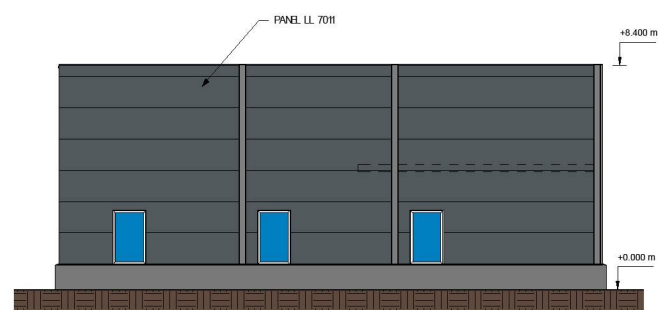

| | | | |
|---|-------------------|---|-------------------|
| REF | ÄNDRINGSOR | SEN | ORSAK |
| LLENTAB AB Hålländsvägen 29 456 34 Kungälv PHONE +46 523 700 00 E-MAIL info@lentarab.se | | | |
| | |  WWW.LLENTAB.SE | |
| BYGGH | NEW PROJEKT | | |
| FAST | NEW | | |
| KOMMUN | NEW TOWN | | |
| ANSVARIG | PROJEKT | ANSVARIG | PROJEKT |
| 2021-05-11 | Jan-Olof Karlsson | 2021-05-11 | Jan-Olof Karlsson |
| LANGSIDER COLOR | | | |
| SKALA | FÖRSTÄ | REF | |
| 1:100 | A3D | | |

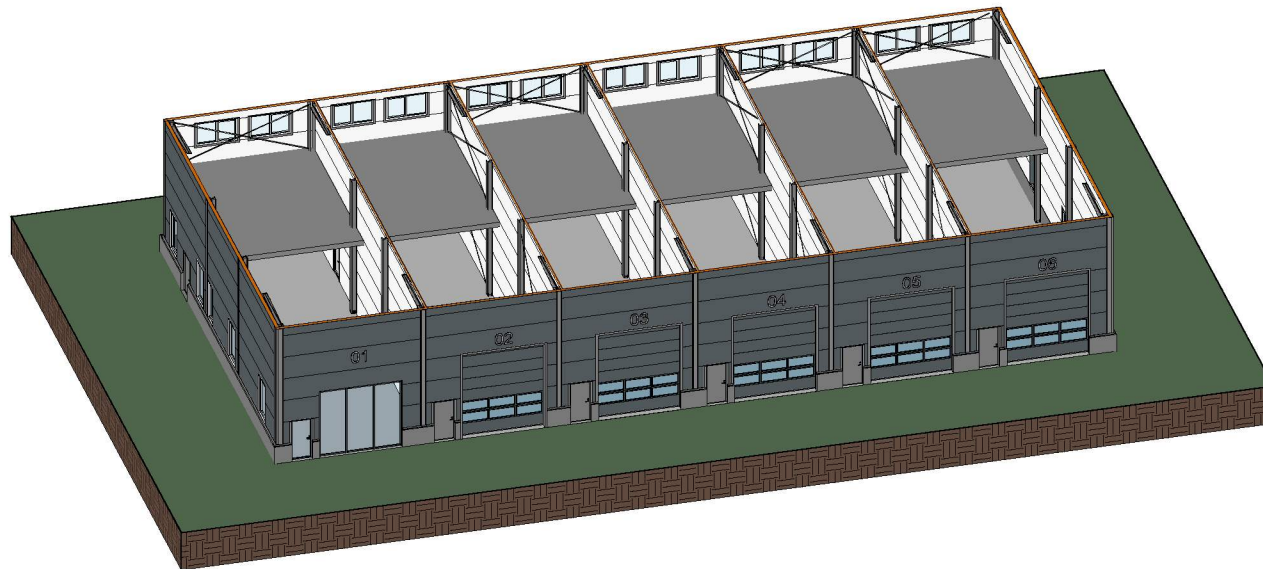
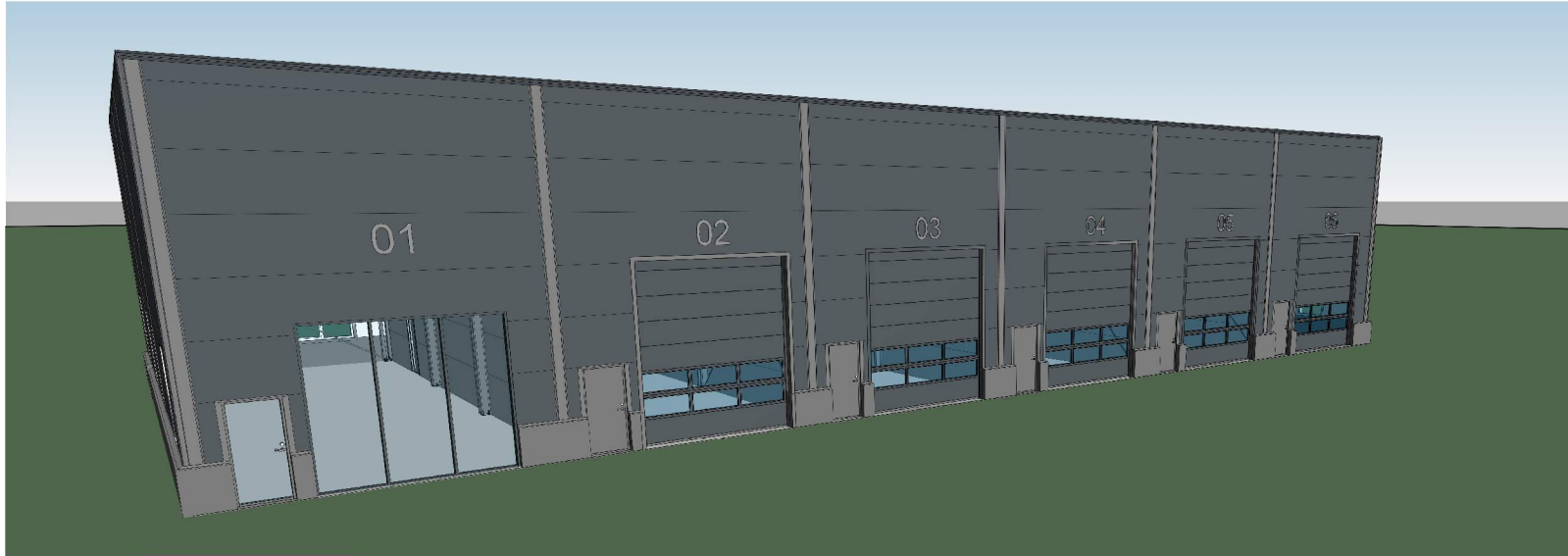

| | | | |
|--|--------------|---|------|
| REF | ÄRREGLAGSBER | REN | DRUM |
| EJ KLAR | | | |
| LLENTAB Årådensvägen 486 34 Kungälv PHONE: +46 523 790 00 E-MAIL: info@lentar.se | |  WWW.LLENTAB.SE | |
| BYGGH | NEW PROJEKT | | |
| FAST | NEW | | |
| KOMMUN | NEW TOWN | | |
| ANSVARIG | PROJEKT | ANSVARIG | |
| 2021-05-11 | 12 | ANSVARIG | |
| 3D VY | | | |
| PROJ | NUMR | REF | |
| 100 | A400 | | |

3D Section steel

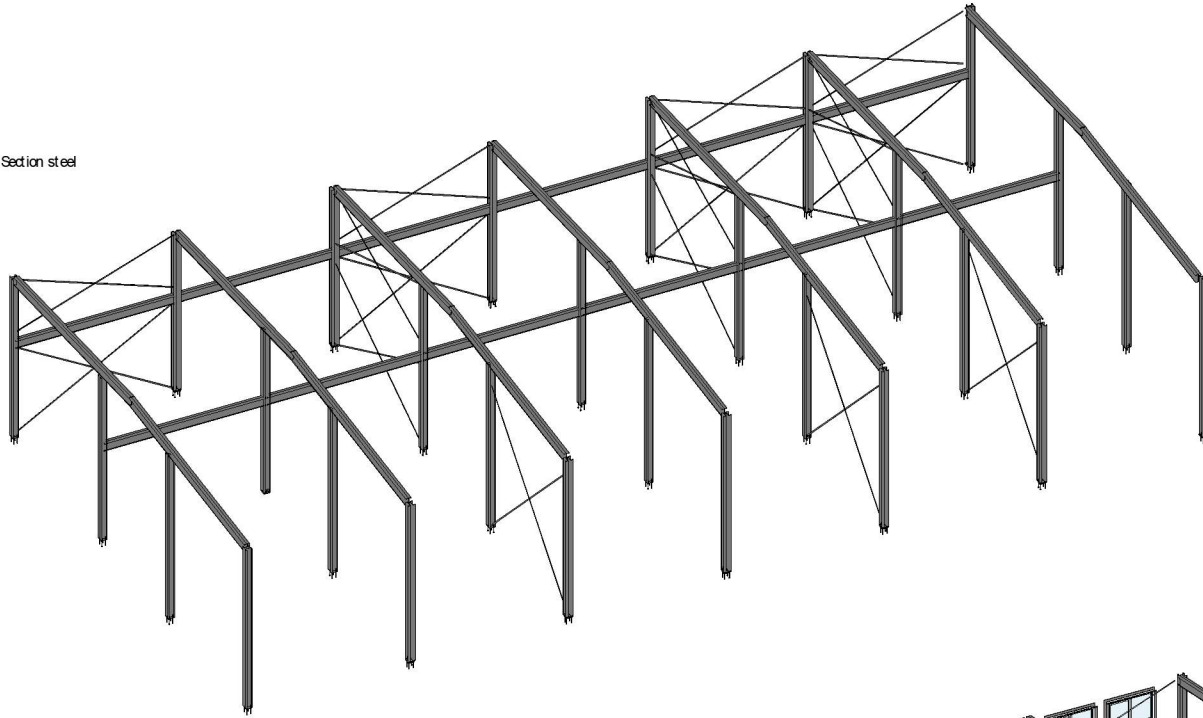

3D Section steel, windows and doors

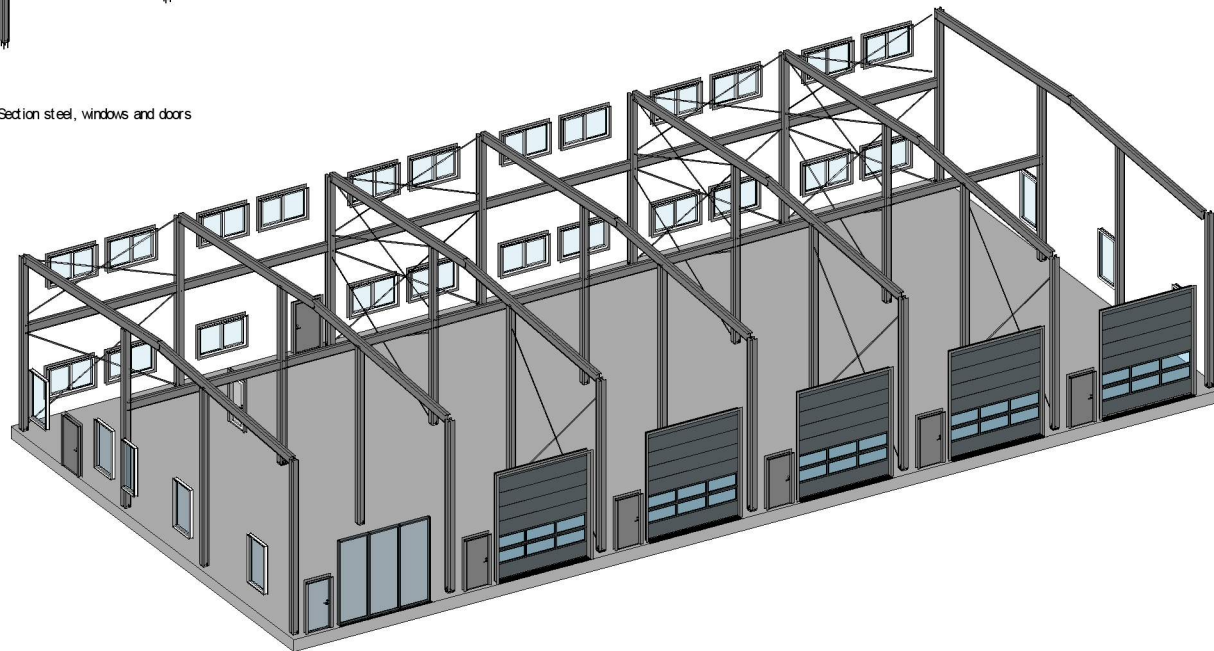

| | | | |
|---|----------------------|-----|-------|
| REF | AKRÖGEGOR | REN | OSTAN |
| EJ KLAR | | | |
| LLENTAB AB Hälsövägen 29 456 34 Kungälv | | | |
| LLENTAB WWW.LLENTAB.SE | | | |
| BYGGH | NEW PROJEKT | | |
| FAST | NEW | | |
| KOMMUN | NEW TOWN | | |
| PROJEKTANT | PROJEKT | | |
| NUMERO | Jörgen Olof Karlsson | | |
| 2021.05.11 | | | |
| 3D VY STOMME | | | |
| BYGG | NUMER | REF | |
| 100 | A4D | | |

GRUNPLAN

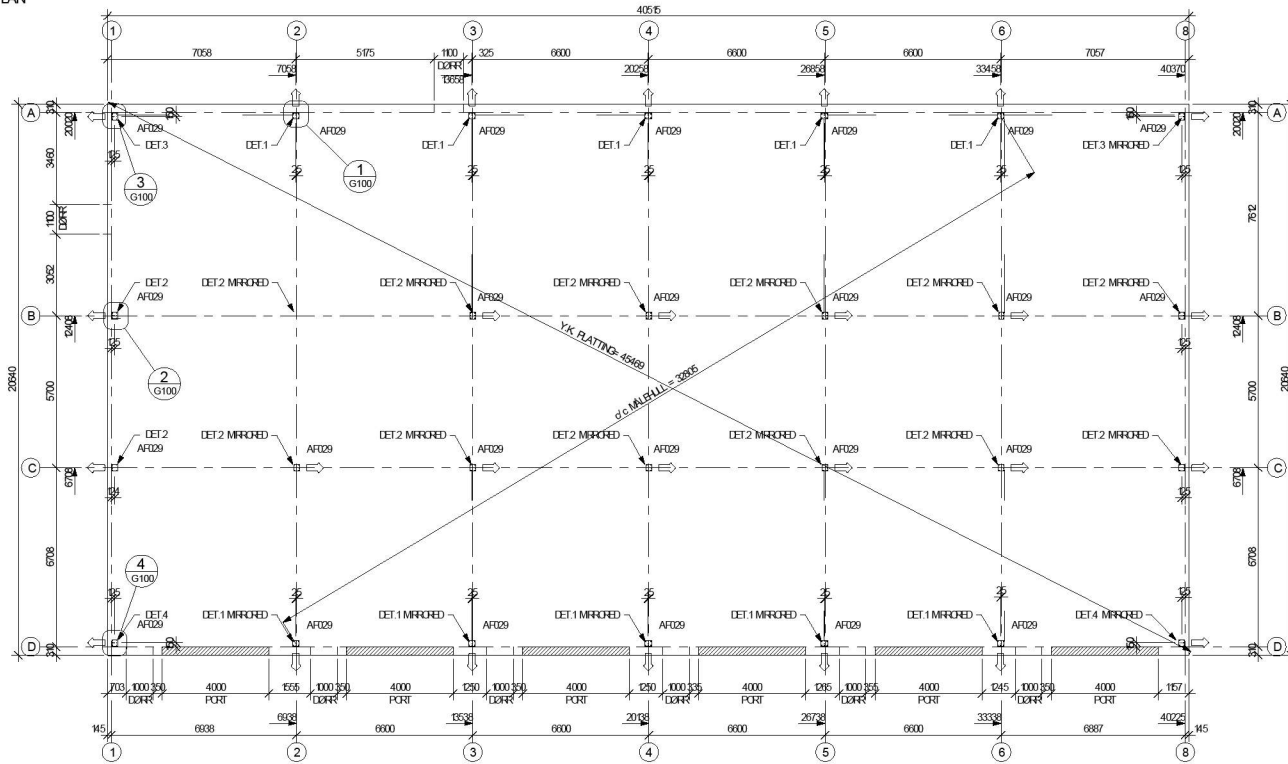

ANVISNINGAR

Rävarfötter infästas med ingjutningsgods. Injutningsgods tillhandhålls av Lientab. Kontrollera att pinskruven är hårt dragen i distansplattan. Det undviker snedställning av pinskruven.

Måttolerans ±5 mm

Santliga mått skall kontrolleras på plats.

Betongkvalitet lägst C25/30

Denna ritning utgör inte tillverkningsunderlag för grundkonstruktion. Beräkning av mått, på betong och armering måste utföras av konstruktör. Denna ritning visar enbart infästningar av hall i grund och mått för dessa.

Avslutningar i plattan, till exempel takavtinningsör eller godsvärme, måste ligga bortom en radie=300 mm från pelarens centrum

I hallen skall hela ytan vara hårdgjord, plan och fri från material/byggskräp. Runt hela hallen, med en bredd av 5 m skall marken vara körbar för truck.

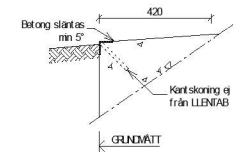
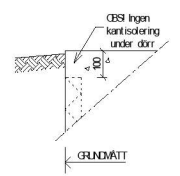

DET. 1 1:10

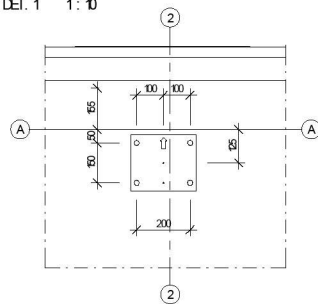

DET. 2 1:10

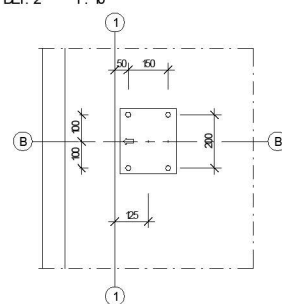

DET. 3 1:10

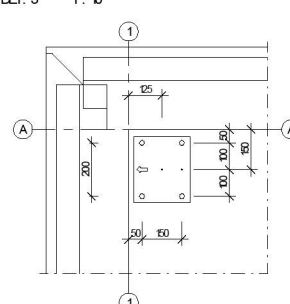

DET. 4 1:10

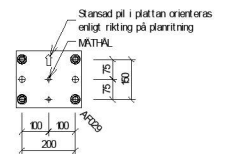
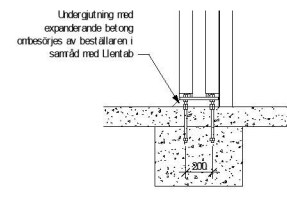
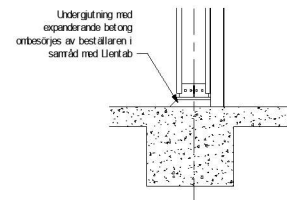
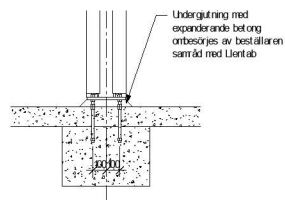
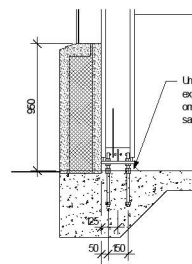
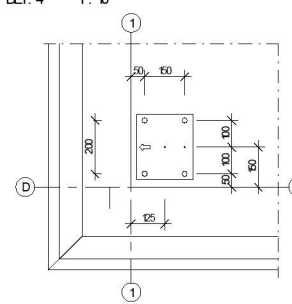

| | | |
|--|------------------|------|
| REF. TÄCKPLÅS | REN | DISK |
| EJ KLAR | | |
| LIENTAB Åländersvägen 486 34 Kungälv PHONE +46 523 790 00 E-MAIL info@lientab.se WWW.LIENTAB.SE | | |
| BYGGH | NEW PROJEKT | |
| FAST | NEW | |
| KOMMUN | NEW TOWN | |
| ANSVARIG | PROJEKT | |
| TEKNIK | Åke Ole Karlsson | |
| 2021 05-11 | 13/00000 | |
| GRUNPLAN GRUNDETALJER | | |
| SKALA 1:100 | NUMR 600 | REF |