



Kumkort			
Tiltakshaver:	ATR eiendom,	Side:	1 av 3
Ansvarlig utførende:	Flage Maskin as	Sist rev.	18.02.2022
Prosjekt:	Nordhordaland Næringspark VA	Dok.Id:	030610-061 B
Prosjektnr.:	21033	Dato /sign.:	

Anleggssted	Nordhordaland Næringspark
Dato	04.04.2022
Registrert av	Mari Røen
Kumnr.	S27



KUMDATA

Kumform	R (Rund)
Kumbredde Innvendig diameter (mm)	400
Bunnseksjon	Rettløp
Kjegle	U (uten kjegle)
Byggemetode	W (PP (polypropylen))
Produsent	Kaczmarek
Stige	Nei
Drenering	U (ingen drenering)

Kumkort		 <small>Bjørkemoen 46 5700 VORØ T.L.F. 55 53 02 00 - FAX. 55 53 02 10 MOB. 46 40 70 70 - www.flagemaskin.no</small>	
Tiltakshaver:	ATR eiendom,	Side:	2 av 3
Ansvarlig utførende:	Flage Maskin as	Sist rev.	18.02.2022
Prosjekt:	Nordhordaland Næringspark VA	Dok.Id:	030610-061 B
Prosjektnr.:	21033	Dato /sign.:	

Kumskisse, bilde nr. 1

Kommentar til skisse: Bunnseksjon har rettløp

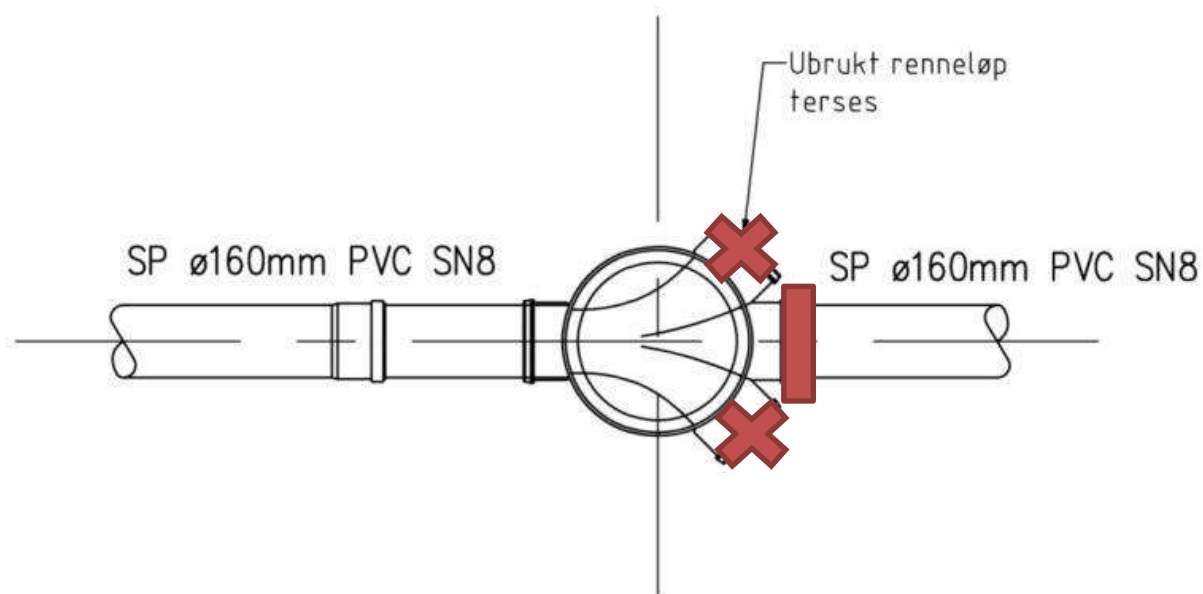

PLAN MINISTAKEKUM

18.02.2022 14:14

M=1:20

Kumkort			
Tiltakshaver:	ATR eiendom,	Side:	3 av 3
Ansvarlig utførende:	Flage Maskin as	Sist rev.	18.02.2022
Prosjekt:	Nordhordaland Næringspark VA	Dok.Id:	030610-061 B
Prosjektnr.:	21033	Dato /sign.:	

Kumskisse, bilde nr. 2

Kommentar til skisse: Bunnseksjon har rettløp

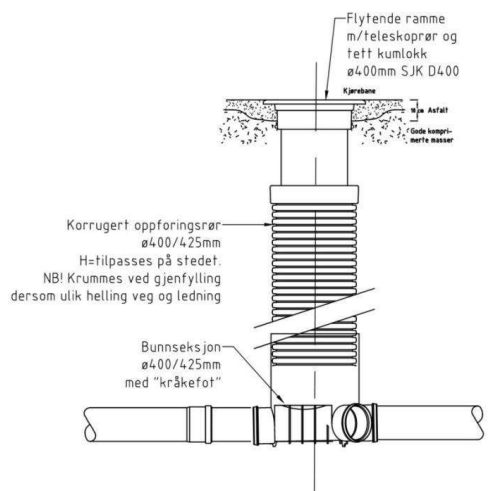

SNITT MINISTAKEKUM
M=1:20

18.02.2022 14:14

